

Yale[®]

Electric Chain Hoist Series CPE

Mod. CPE/F

Capacity 1600 kg - 5000 kg

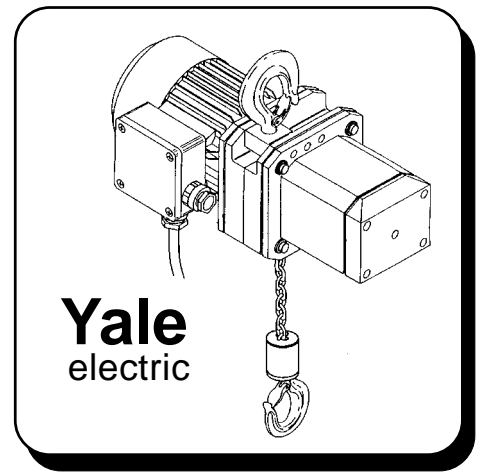

Operating and Maintenance Manual Spare Parts Catalog

Yale[®]

Yale Industrial Products GmbH

P. O. Box 10 13 24 • D-42513 Velbert, Germany
Am Lindenkamp 31 • D-42549 Velbert, Germany
Tel. 20 51-600-0 • Fax 20 51-600-127

Ident.-No. 09900069 / 10.02

Yale Electric Chain Hoist CPE

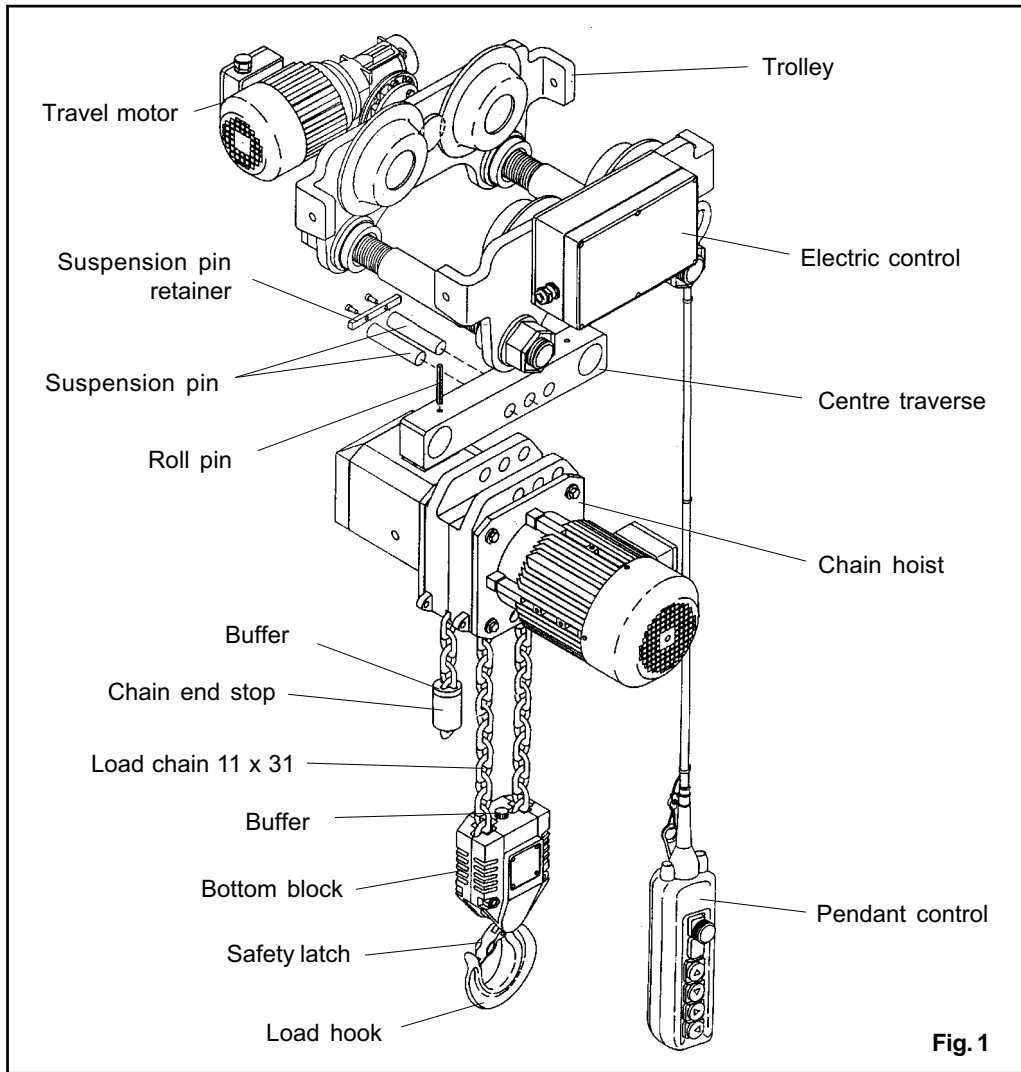

Fig. 1

Technical data electric chain hoist							Technical data electric trolley				
Model	Capacity [kg]	Number of chain falls	Motor rating ED [%]	Motor [kW]	Lifting speed(s) [m/min]	FEM group	Beam widths [mm]	Min. curve radius	Travel speed(s) [m/min]	Motor [kW]	Motor rating ED %
CPE 16-8 CPEF 16-8	1600	1	40 40 / 20	2,3 2,3 / 0,52	8 8 / 2	1 Am	98 -180 or 180 - 300	1800	11 11 / 2,8	0,37 0,3 / 0,09	40 40 / 20
CPE 20-8 CPEF 20-8	2000	1	25 25 / 15	2,8 2,8 / 0,7	8 8 / 2	1 Bm	98 -180 or 180 - 300	1800	11 11 / 2,8	0,37 0,3 / 0,09	40 40 / 20
CPE 25-5 CPEF 25-5	2500	1	40 40 / 20	2,3 2,3 / 0,52	5 5 / 1,25	1 Am	98 -180 or 180 - 300	1800	11 11 / 2,8	0,37 0,3 / 0,09	40 40 / 20
CPE 30-5 CPEF 30-5	3000	1	25 25 / 15	2,8 2,8 / 0,7	5 5 / 1,25	1 Bm	98 -180 or 180 - 300	1800	11 11 / 2,8	0,37 0,3 / 0,09	40 40 / 20
CPE 32-4 CPEF 32-4	3200	2	40 40 / 20	2,3 2,3 / 0,52	4 4 / 1	1 Am	98 -180 or 180 - 300	1800	11 11 / 2,8	0,37 0,3 / 0,09	40 40 / 20
CPE 40-4 CPEF 40-4	4000	2	25 25 / 15	2,8 2,8 / 0,7	4 4 / 1	1 Bm	98 -180 or 180 - 300	1800	11 11 / 2,8	0,37 0,3 / 0,09	40 40 / 20
CPE 50-2 CPEF 50-2	5000	2	40 40 / 20	2,3 2,3 / 0,52	2,5 2,5 / 0,6	1 Am	98 -180 or 180 - 300	1800	11 11 / 2,8	0,37 0,3 / 0,09	40 40 / 20

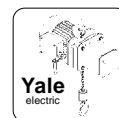

TABLE OF CONTENTS	PAGE
1. GENERAL INFORMATION	3
2. OPERATING INSTRUCTIONS	3
2.1 Correct operation	3
Maximum capacity	3
Danger zones	3
Attaching the hoist / trolley	3
Temperature range	4
Regulations	4
Maintenance / repair	4
2.2 Incorrect operation	4
2.3 Initial operation	4
Inspection before initial operation	4
Inspection before starting work	4
Inspection of load chain	4
Inspection of chain end stop	4
Inspection of chain reeving	4
Inspection of suspension and load hooks	5
Attaching the load	5
Inspect the traverse (for trolleys)	5
Check adjustment of trolley width	5
3. ASSEMBLY	5
3.1 Inspection before assembly	5
3.2 Electric chain hoist with hook suspension (Standard version)	5
3.3 Electric chain hoist with trolley	5
Assembly of the trolley	6
2.4 Electrical connection	6
Preparation	6
Mains supply connection	6
4. FUNCTIONAL TEST AFTER ASSEMBLY	6
5. OPERATION	7
Installation, service, operation	7
Traversing the trolley	7
Attaching the load	7
Lifting / lowering the load	7
Emergency stop	7
6. SERVICE	8
6.1 Daily checks	8
6.2 Regular inspections, service and testing	8
6.3 Load chain	9
Lubricating the load chain	9
Inspecting the load chain for wear	9
Replace the load chain	9
1-strand design	9
2-strand design	9
6.4 Load and suspension hooks	10
6.5 Trolleys	10
6.6 Electric chain hoist in general	10
6.7 Overload protection device	10
6.8 Gearbox	10
Check oil level	10
Oil change	10
Disassembly and reassembly	11
6.9 Maintenance of the motor	11
Motor	11
Disc brake	11

1. GENERAL INFORMATION

Attention: All users must read these operating instructions carefully prior to the initial operation. These instructions are intended to acquaint the user with the hoist / trolley and enable him to use it to the full extent of its intended capabilities.

The operating instructions contain important information on how to handle the hoist / trolley in a safe, correct and economic way. Acting in accordance with these instructions helps to avoid dangers, reduce repair costs and downtime and to increase the reliability and lifetime of the hoist / trolley.

Anyone involved in doing any of the following work with the hoist / trolley must read the operating instructions and act accordingly:

- operation, including preparation, trouble shooting and cleaning
- maintenance, inspection, repair
- transport

Apart from the operating instructions and the accident prevention act valid for the respective country and area where the hoist / trolley is used, also the commonly accepted regulations for safe and professional work must be adhered to.

Every unit leaving the factory is furnished with a test certificate that shows the serial number of the hoist / trolley. This certificate has to be filed together with the inspection manual (see page 30).

The continuous sound level at the place of work is equal to 73 dB. The measurements were taken at a distance of 1 m from the hoist at 9 positions in accordance with DIN 45635, precision class 2.

2. OPERATING INSTRUCTIONS

2.1 Correct operation

Maximum capacity

- The Yale electric chain hoist model CPE is designed to lift and lower loads up to the rated capacity. The lifting capacity indicated on the hoist / trolley is the maximum safe working load which must not be exceeded.

Danger zones

- Do not lift or transport loads while personnel are in the danger zone.
- Do not allow personnel to pass under a suspended load (see Fig. 2)
- After lifting or tensioning, a load must not be left unattended for a longer period of time.
- Start moving the load only after it has been attached correctly and all personnel are clear of the danger zone.

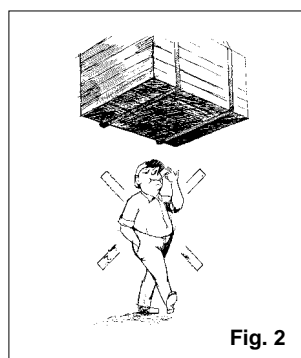

Fig. 2

Attaching the hoist / trolley

- The operator must ensure that the hoist / trolley is attached in a manner that does not expose himself or other personnel to danger by the hoist, trolley, chain(s) or the load.

Temperature range

• The hoist / trolley can be operated in ambient temperatures between -10°C und $+50^{\circ}\text{C}$. Consult the manufacturer in case of extreme working conditions.

Note: At ambient temperatures below 0°C check the brake is not frozen.

Regulations

• The accident prevention act and/or safety regulations of the respective country for using manual and electric hoists must be strictly adhered to. In Germany these are VBG 8, VBG 9, VBG 9a, ZH 1/25, ZH 1/27, and VDE 0100 resp. VDE 0130.

Maintenance / Repair

• In order to ensure correct operation, not only the operating instructions, but also the conditions for inspection and maintenance must be complied with. If defects are found stop using the hoist / trolley immediately.

Attention: Before starting work on electrical components switch OFF the main current switch and secure it against unintentionally being switched back on.

2.2 Incorrect operation

- Do not exceed the rated capacity of the hoist / trolley.
- Do not use the hoist / trolley for the transportation of people (Fig. 3)
- Welding on hook and load chain is strictly forbidden. The load chain must never be used as a ground connection during welding (Fig. 4).

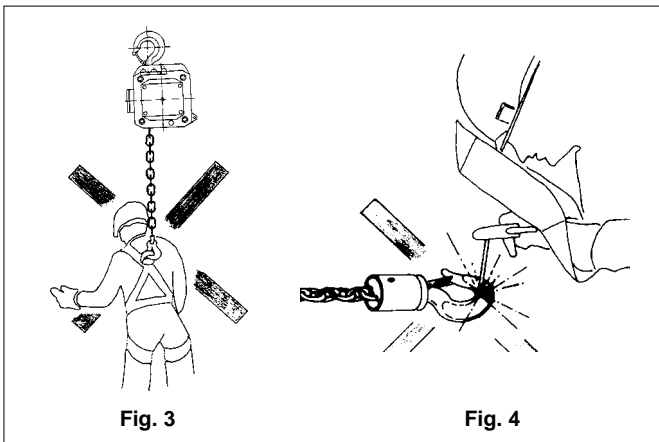

- Avoid side pull, i.e. side load on either housing or bottom block (Fig. 5). Lift only when the load chain forms a straight line between both hooks.
- The load chain must not be used for lashing purposes (sling chain) (Fig. 6).
- Do not knot or shorten the load chain by using bolts, screws, screwdrivers or other devices (Fig. 7). Do not repair chains installed in the hoist.
- Do not remove the safety latch from the suspension or load hooks (Fig. 8).
- Do not use the chain end stop as an operational limit device (see Fig. 1 - chain end stop).
- Do not throw the hoist hoist or trolley down. Always place it properly on the ground.

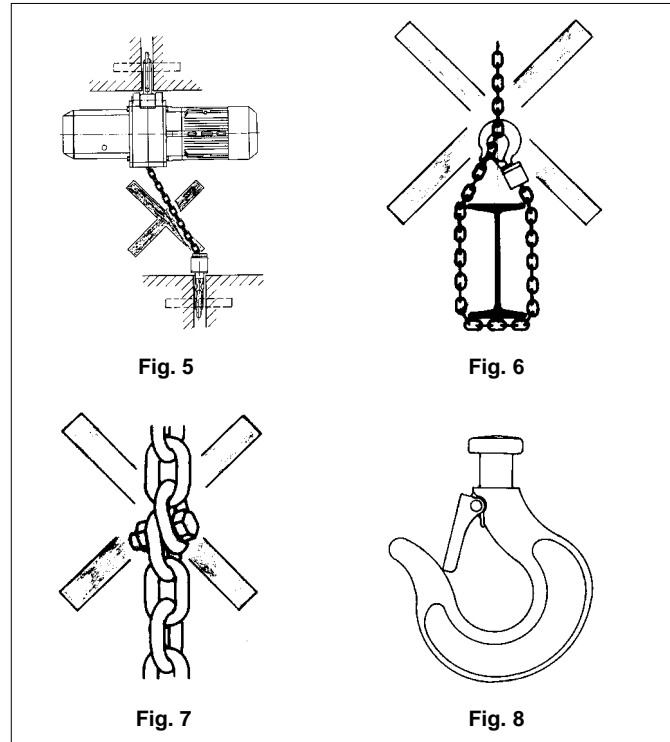

2.3 Initial operation

Inspection before initial operation

Each hoist / trolley must be inspected prior to initial operation by a competent person and any failures be removed. The inspection is visual and functional and shall establish that the hoist is safe and has not been damaged by incorrect transport or storage. Inspections should be made by a representative of the manufacturer or the supplier although the company can assign its own suitably trained personnel. Inspections are instigated by the user.

Inspection before starting work

Before starting work inspect the hoist / trolley, chains and all load bearing components every time for visual defects. Furthermore test the brake and make sure that the load and hoist / trolley are correctly attached by carrying out a short work cycle of lifting and lowering resp. travelling in both directions. Selection and calculation of the proper suspension point and beam construction are the responsibility of the user.

Inspection of load chain

Inspect the chain for sufficient lubrication any visually check for external defects, deformations, superficial cracks, wear or signs of corrosion.

Inspection of chain end stop

The chain end stop must be connected to the free (idle) chain strand (see Fig. 1 - chain end stop).

Inspection of chain reeving

All units with two or more chain strands should be inspected prior to initial operation for twisted or kinked chains. The chains of 2-strand hoists may be twisted if the bottom block was rolled over (Fig. 9).

Inspection of suspension and load hooks

Inspect suspension and load hooks for deformations, damage, cracks, wear or signs of corrosion.

Attaching the load

The load must always be seated in the saddle of the hook. Never attach the load to the tip of the load hook. This also applies to the suspension hook (Fig. 10).

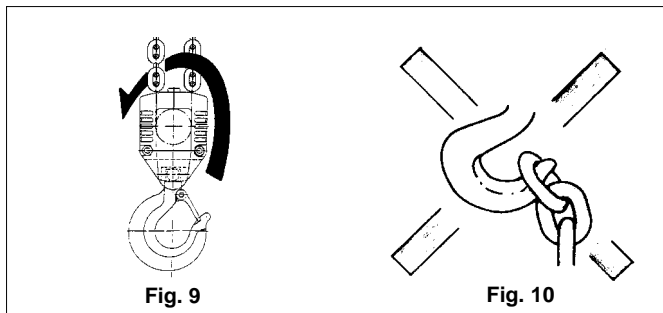

Inspect the traverse (for trolleys)

Inspect the traverse for correct assembly and visually check for external defects, deformations, superficial cracks, wear or signs of corrosion. Especially make sure that the roll pins are properly fitted to the centre traverse (Fig. 12).

Check adjustment of trolley width

On chain hoists without suspension hook (CPE-VTP/G/E) check that the clearance between the trolley wheel flange and the beam outer edge is equal on both sides and within the tolerances given (see page 6, 2. - 3.). Enlarging the clearances, e.g. to enable the trolley to negotiate tighter curves, is forbidden.

3. ASSEMBLY

3.1 Inspection before assembly

- Check for transport damage
- Check for completeness
- Check that the capacity indication on hoist and bottom block match.

3.2 Electric chain hoist with hook suspension (Standard version)

The suspension hook is connected to the hoist with two suspension pins. Independent of how the hoist is reeved the load hook must always hang vertically under the suspension hook. In 1-strand configuration the suspension hook is to be installed centred on the marking "1/1", in 2-strand configuration centred on the marking "2/1" (see Fig. 11).

Attention: Secure the two suspension pins with locking plate after assembly.

Selection and calculation of the suitable suspension point and beam construction are the responsibility of the user.

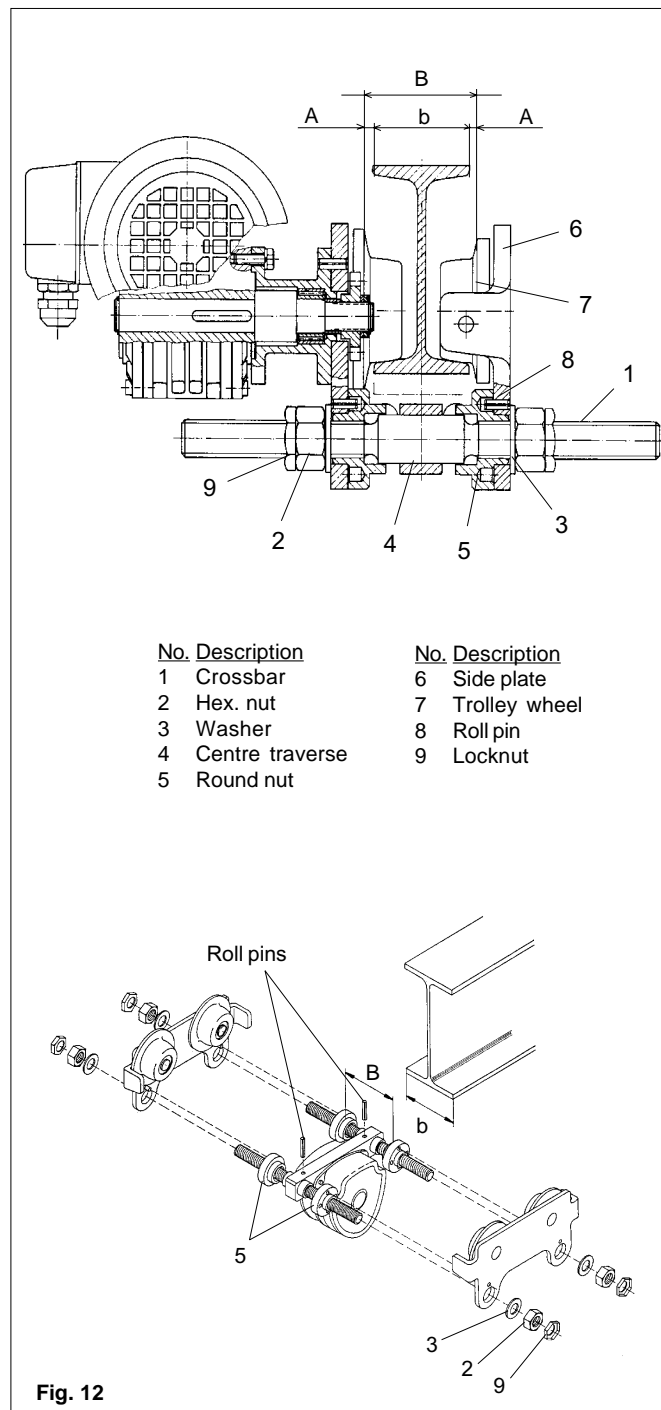
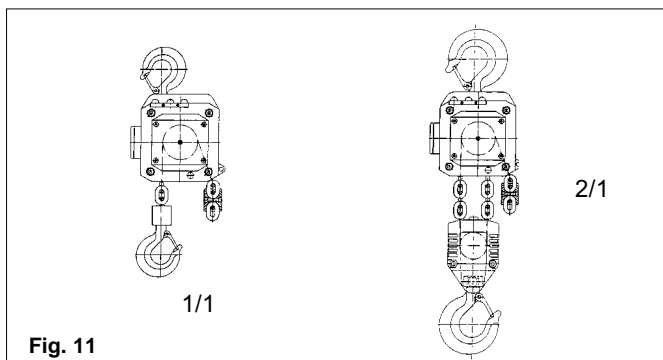

No.	Description	No.	Description
1	Crossbar	6	Side plate
2	Hex. nut	7	Trolley wheel
3	Washer	8	Roll pin
4	Centre traverse	9	Locknut
5	Round nut		

3.3 Electric chain hoist with trolley

The trolleys are supplied pre-assembled for beam width A or B (see table below). This is indicated on the name-plate. Before installation ensure that the trolley width is correct for the intended carrying beam.

Beam range	Flange width mm		Flange thickness mm max
	min	max	
A	98	180	27
B	180	300	27



Yale Electric Chain Hoist CPE

Assembly of the trolley (see Fig. 12)

1.) Unscrew the locking nuts (item 9) and hex. nuts (item 2) from the crossbars (item 1) and remove both side plates (item 6) from the trolley.

2.) Measure the flange width of the beam (see Fig. 11 - measurement "b").

3.) Adjust measurement "B" between the shoulders of the round nuts (item 5) on the threaded crossbars (item 1). Ensure that the 4 bores in the round nuts face towards the outside. Adjust the measurement "B" to equal measurement "b" plus 4 mm. Measurement "A" must be 2 mm on either side and the suspension traverse (item 4) must be centred between the round nuts.

4.) Replace one side plate (item 6):

Replace one side plate ensuring that the roll pins (item 8) engage into one of the bores in the round nuts. To achieve this it may be necessary to rotate the round nuts slightly.

5.) Replace the washers (item 3) and tighten the hex. nuts (item 2). Screw on the locknuts (item 9) fingertight and tighten a further 1/4 to 1/2 turn.

Attention: The locknuts must always be fitted.

6.) Loosely replace the second side plate (item 6) on the crossbars (item 1). The washers (item 3), hex. nuts (item 2) and locknuts (item 9) can be fitted loosely.

7.) Raise the complete pre-assembled trolley to the carrying beam.

8.) Engage the second side plate (item 6) ensuring that the roll pins (item 8) engage into one of the bores in the round nuts (item 5). To achieve this it may be necessary to rotate the round nuts slightly.

9.) Tighten the hex. nuts (item 2) on the second side plate. Tighten the locknuts (item 9) fingertight and then a further 1/4 to 1/2 turn.

Attention: The locknuts must always be fitted.

10.) By traversing the trolley check the following:

- that a clearance of 2 mm is maintained on each side between the trolley wheel flanges and the beam outer edge.
- that the suspension traverse is centred below the beam.
- that all 4 locknuts (item 9) are fitted.

11.) Model CPE-VTG only:

To fit the hand chain position the slot on the outer edge of the hand chain wheel below the chain guide. Place any one link of the endless hand chain vertically into the slot and turn the hand chain wheel until the link has passed the chain guides on both sides.

Attention: Do not twist the hand chain when fitting. Geared trolleys are moved by pulling the hand chain.

3.4 Electrical connection

Attention

Work at electrical installations may be carried out by electrical experts only. The local regulations have to be strictly observed, in Germany DIN 7100 / VDE 0100 and DIN 57113 / VDE 0113.

Preparation

- Before beginning work on electrical components the mains current switch must be switched OFF and secured against unintentionally being switched back on.
- Before connecting the chain hoist ensure that the electrical data on the nameplate match the local supply specifications.
- The mains supply cable must be an insulated cable with 4 flexible leads. The ground (earth) lead must be longer than the live leads. For wire cross-section and fusing see table on page 7.
- The length of the pendant control cable is determined by working conditions. Attach the tension relief wire in a manner that the pendant control cable hangs load-free.
- Wiring and terminal connecting diagrams are included with the hoist.

Mains supply connection

1.) The mains supply cable must be connected to the electric chain hoist before it is connected to the mains supply.

2.) On chain hoists with an electric trolley (CPE-VTE) the three phases of the mains supply are to be connected to the terminal strip within the terminal box on the trolley. The ground/earth wire is to be connected to the special ground/earth connection within the terminal box of the chain hoist.

3.) On chain hoists without electric trolley the mains supply and the ground/earth wire are to be connected to the terminal strip within the terminal box of the chain hoist.

4.) After removing the terminal box cover, connect the wiring as shown on the wiring diagram label inside the terminal box cover.

Attention: On hoists with direct control the ground/earth wire should always be connected according to the wiring diagram. Should the mains supply source not provide a ground (earth) connection please consult the manufacturer.

5.) After replacing the terminal box cover, connect the other end of the supply cable to the mains supply.

6.) Check the motor's direction of rotation.

The wiring diagram included has been drawn for a normal, clockwise rotating installation. Should the user's mains supply not fulfil these requirements, e.g. the hoist lowers when lift is selected (or vice versa) switch the unit OFF immediately and exchange two of the three phase connections in the mains connection.

Attention:

Under no circumstances may the wiring in the pendant control be tampered with.

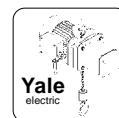

Model	P _n [kW]	ED [%]	I _a /I _n	I _n [A]	Fuse (slow) [A]	Wire cross section in mm ² for cable length		
						0-50 m	50-100 m	100-150 m
CPE 16 CPE 25 CPE 32 CPE 50	2,3	40	4,7	5,3	16*	1,5	1,5	2,5
CPE 20 CPE 30 CPE 40	2,8	25	4,7	6,4	16*	2,5	2,5	-

Model	P _n [kW]	ED [%]	I _a /I _n	I _n [A]	Fuse (slow) [A]	Wire cross section in mm ^Δ for cable length		
						0-50 m	50-100 m	100-150 m
CPEF 16 CPEF 25 CPEF 32 CPEF 50	0,58/2,3	20/40	1,8/4,4	3,3/5,5	16*	1,5	2,5	2,5
CPE 20 CPE 30 CPE 40	0,7/2,8	15/25	1,8/4,4	4,0/6,8	16*	2,5	2,5	-

all data for 400V, 3 Phase, 50 Hz

* for direct control (for low voltage contactor control = 10A)

4. FUNCTIONAL CHECK AFTER ASSEMBLY

Prior to operating the hoist, grease the trolley pinions (manual geared and electric trolleys) and lubricate the load chain when it is not under load (see page 8).

Before the hoist is put into regular service, following additional inspections must be made:

- Are all screwed connections on hoist and trolley tight and are all locking devices in place and secure?
- Are the end stops on the trolley runway in place and secure?
- Is the chain drive correctly reeved?
- Is the chain end stop correctly fitted to the loose end of the load chain?
- All units equipped with two or more chain strands should be inspected before initial operation for twisted or kinked chains. The chains of 2-strand hoists may be twisted if the bottom block is rolled over.
- Perform an operation cycle without load. The chain should move in a steady, smooth way. Check the function of the overload device by raising the bottom block against the hoist body (max. 5 sec.).
- Check the brake function when lifting and lowering. The braking distance must not be more than 50 mm.
- Traverse the trolley (if available) the complete length of the trolley runway ensuring that the 2 - 4 mm lateral clearance between the trolley wheel flange and the beam outer edge is maintained at all times. Check that beam end stops are positioned correctly and secure.

5. OPERATION

In addition to the recommendation in section 1, following rules must be strictly maintained to ensure the safe operation of the hoist:

Installation, service, operation

Users delegated to install, service or independently operate the hoist must have had suitable training and be competent.

Users are to be specifically nominated by the company and must be familiar with all relevant safety regulations.

Traversing the trolley

Plain trolleys: Pull on the load chain of the hoist.

Attention: Never pull on the pendant control cable.

Geared trolleys: By operating the trolley hand chain.

Electric trolleys: By operating the 4- resp. 3-button.

For trolleys with two speeds: The first stage of button depression activates the slow speed, further depression activates the fast speed. Use the slow speed for short periods only.

Consider the braking distance of the trolley. Do not use the beam end stops as operational limit devices

Attaching the load

Attach the load to the hoist using only approved and certified slings or lashing devices. Never use the load chain as sling chain. The load must always be seated in the saddle of the hook. Never attach the load to the tip of the hook. Never remove the safety latch from suspension or load hooks.

Lifting / lowering the load

The load is lifted by depressing the 5-button, it is lowered by depressing the 6-button. For hoists with two speeds: The first stage of button depression activates the slow speed, further depression activates the faster speed. Use the slow speed for short periods only. Do not use the chain end stop as operational limit device.

Emergency stop

All movement can be immediately halted by depressing the red, mushroom shaped button on the pendant control.

Attention: Operating the red emergency button does NOT automatically disconnect the mains supply to hoist or trolley. To release the emergency stop, rotate the button in an anti-clockwise direction.



Yale Electric Chain Hoist CPE

6. SERVICE

- Service and inspections may only be carried out by a competent person.
- The inspection must determine that all safety devices are present and fully operational and covers the condition of the hoist, lifting gear, accessories and supporting constructions.
- The service intervals and inspections noted are for normal working conditions. Adverse working conditions, e.g. heat or chemical environments, can dictate shorter periods.
- The Yale electric chain hoists conform to FEM group 1Am resp. 1Bm in accordance with FEM 9.511. This results in a theoretical service lifetime of 800 resp. 400 operating hours under full load. This is equivalent to 10 years under normal operating conditions. After this period the hoist requires a general overhaul. Further information is contained in VBG 9 resp. FEM 9.755.

6.1 Daily checks

- 1.) Visually check the pendant control switch and cable for damage.
- 2.) Check that the brake functions correctly.
- 3.) Check that the overload safety device functions correctly.
- 4.) Electric chain hoists with trolley:
 - Check that the trolley runway is free from obstructions
 - Check that the end stops on the trolley runway are fitted and secure.

6.2 Regular inspections, service, testing

According to national and international safety regulations hoisting equipment must be inspected at least annually by a competent person. Adverse working conditions, e.g. heat or chemical environments, can dictate shorter periods. The commissioning and inspection details can be noted on the test certificate delivered with the hoist or on page 30 of this manual. Repairs may only be carried out by specialist workshops that use original Yale spare parts.

Attention: Tests must - as far as possible - be carried out in an unloaded condition and the hoist / trolley currentless.

Inspection and Maintenance	Initial checks			Periodical checks		
	during commissioning	after 50 operating hours	after 200 operating hours	daily	after 200 operating hours	annually
electrical installation and power supply	•					•
Pendant control and support wire	•	•		•		
Lubricate load chain	•	•	•		•	
Check for wear in chain drive		•	•		•	
Check function of overload device	•			•		
Check function of brake	•			•		
Inspect chain bolts for cracks		•				•
Inspect suspension and load hook for cracks and deformation		•				•
Check screwed connections for tightness		•				•
Inspect trolley components for cracks and deformation		•				•
Check oil level	•	•			•	
Oil change			•			•
Inspect motor and transmission of hoist						•
Inspect motor and transmission of trolley						•
Lubricate geared trolley drive						•

6.3 LOAD CHAIN

The Yale load chain is grade 80 chain with the dimensions 11 x 31 mm. The CPE electric hoists are specially designed to use this type of chain. For this reason only chains that have been approved by the manufacturer may be used in these hoists.

Lubricating the load chain

The load chain is to be lubricated before initial operation and every 3 months but the latest after 200 operating hours. Adverse working conditions, e.g. excessive dust or continued heavy duty can dictate shorter periods between lubrication.

- Before the chain is lubricated it must be cleaned. Flame cleaning is forbidden. Use only cleansing methods and agents that do not corrode the chain material. Avoid cleansing methods that can lead to hydrogen brittleness, e.g. spraying or dipping chain in caustic solvents. Also avoid surface treatments that can hide cracks and flaws or other surface damage.
- The chain must be lubricated in a no-load condition so that lubricant can enter between the links, e.g. by dipping in oil.
- Motor oil of the viscosity 100, e.g. Shell Tonna T68 can be used to lubricate the chain. For very dusty applications use a dry lubricant.

Inspecting the load chain for wear

Load chains must be inspected every 3 months or the latest after 200 operating hours (see VBG 8 § 27 or local regulations).

Visually inspect the chain over its full length for deformation, cracks, flaws, elongation, wear or corrosive pitting.

Link chains must be replaced when the nominal thickness "d" on any part of the chain has been reduced by more than 10% or when the pitch "t" is elongated by more than 2% or over 11 pitches (11 x t) by 2%. Nominal dimensions and wear limits are shown in the following table.

Chains that do not fulfil all requirements must be replaced immediately.

Link chain 11 x 31 grade 80			
Inspection	Dimension	Nominal value [mm]	Wear limit [mm]
Length over 11 pitches	11 · t	341	347
Length of 1 pitch	t	31	32
Mean thickness	$\frac{d_1 + d_2}{2}$	11,3	10,2

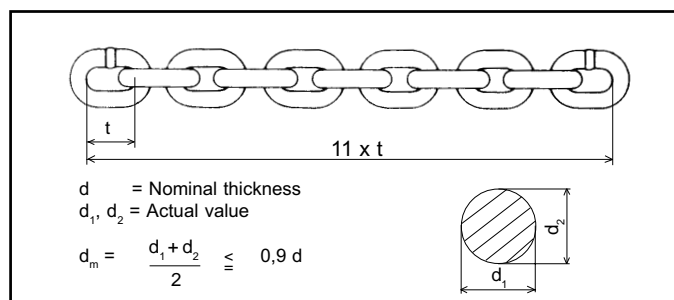

Replace the load chain

1-strand design

1. Disassemble bottom block
Remove the circlip with suitable pliers. Raise the swivel tube in the direction of the chain and tap out the chain bolt with a drift.

Attention: Do not damage the chain bolt bore.

2. Remove the chain end stop.
Remove the 2 screws. The chain is now free.

3. Fitting the new chain
Cut the second to last link open on the loose end of the load chain to form a "C". Remove the last link and connect the new chain. The new chain must be fitted so that the welds on the standing links face towards the chain guide and away from the load sheave. Operate the hoist in the lowering direction to feed the chain through the hoist.

4. Fitting lower block and chain end stop
Slide the end buffers over the loose ends of the load chain and refit bottom block and chain end stop. The chain end stop must be fitted so that at least 1 link remains free (see Fig. 1)

5. Before initial operation lubricate the unloaded chain and test all hoist functions under no-load condition.

2-strand design

1. Remove the chain anchor bolt
The chain anchor bolt is situated on the underside of the hoist body. With an Allen key remove the grub screw that serves as locking device. Tap out the chain anchor bolt with a drift from the other side.

Attention: Do not damage anchor bolt or bore.

2. Pull the load chain through the bottom block and remove the chain end stop.

3. Fitting the new chain
Cut the second to last link open on the loose end of the load chain to form a "C". Remove the last link and connect the new chain. The new chain must be fitted so that the welds on the standing links face towards the chain guide in the housing. Operate the hoist in the lowering direction to feed the chain through the hoist.

4. Replace chain end stop
Slide the buffer pad over the loose end of the load chain and refit the chain end stop ensuring that at least 1 link remains free (see Fig. 1).

5. Fitting the chain anchor bolt
Inspect the chain anchor bolt for flaws, cracks or burrs. Enter the last link of the other load chain end into the slot in the underside of the hoist body. Attention: The chain must not be twisted. Now enter the chain anchor bolt through the side bore. Move the last link back and forth while entering the chain anchor bolt to ensure that it is not trapped and damaged by the anchor bolt. Secure the anchor bolt with the grub screw.

6. Assemble the bottom block
Check the idler sheave for damage. Position the load chain over the idler sheave ensuring that the welds on the standing links face away. Grease the needle bearings in the bottom block halves. Place the load hook assy in the slot provided in one of the bottom block halves and push the complete unit onto the idler sheave. Ensuring that the buffer pad is situated correctly in its groove replace the second bottom block half and secure with the screws.



Yale Electric Chain Hoist CPE

7. Functional test

All units with two or more chain strands must be inspected before every operation for twisted or kinked chains. Chains on 2-strand units may become twisted if the bottom block is rolled over. If a strand is twisted disconnect it from the hoist and re-thread it correctly. In some cases it may be necessary to remove the last link.

8. Before initial operation lubricate the unloaded chain and test all hoist functions under a no-load condition.

6.4 Load and suspension hooks

Inspect the hooks for deformation, damage, surface cracks, wear and signs of corrosion as required but **at least annually**. Adverse working conditions may dictate shorter periods. Hooks that do not fulfill all requirements must be replaced immediately, Welding on hooks to compensate for wear or damage is not permissible. Hooks must be replaced when the mouth of the hook has opened more than 10% (Fig.14) or the nominal value of other dimensions has decreased by 5% due to wear. Nominal dimensions and wear limits are shown in the following table.

Inspection	Dim.	CPE 16 / 20 CPE 25 / 30		CPE 32 / 40 / 50	
		Nominal value mm	Wear limit mm	Nominal value mm	Wear limit mm
Hook saddle	b_2	24	22,8	29,5	28
Hook saddle	h_2	35	33,2	44,5	42,3
Hook opening	a_2	43	47,3	54	59,4

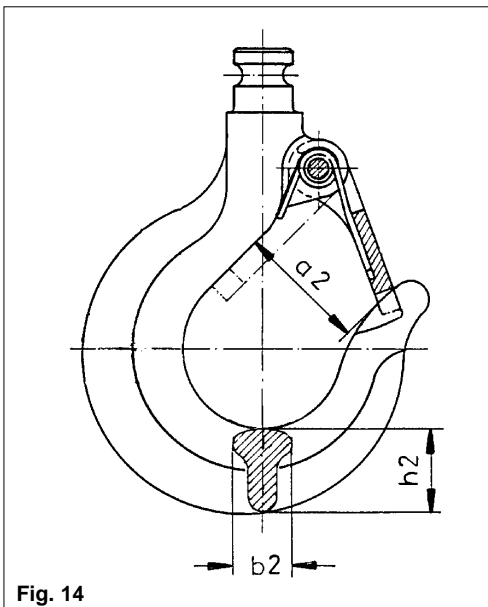

Fig. 14

6.5 Trolleys

In particular check following parts:

- Side plate
For cracks or deformation in particular around the areas of screwed connections.
- Trolley wheels
Visually check for cracks and wear on trolley wheel flanges. Grease the transmission.
- Crossbars
In particular around threaded areas for cracks.
- Fasteners
Check nuts, screws and locking devices for tightness.

6.6 Electric chain hoist in general

In particular check following parts:

- Threaded connections in general
Check all nuts, screws and locking devices for tightness.
- Chain container
Ensure the chain container is securely fastened. Check for cracks or wear.
- Suspension pins
(Connection between hoist and suspension hook resp. trolley) Check for cracks or wear. Ensure all safety devices are in place and secure.

6.7 Overload protection device

The overload protection device (slipping clutch) is factory set to $110\% \pm 10\%$ of the rated capacity and can be checked by lifting a suitable load. If the device slips at the rated capacity load it can be adjusted as follows (see Fig. 19):

- Unscrew the threaded pin (9) which locks the straining screw (45).
- Increase the moment of friction by turning the straining screw (45) in clockwise direction.
- Re-check the adjustment with a suitable load.
- Lock the straining screw (45) with the threaded pin (9).

6.8 Gearbox

The gearbox is practically maintenance-free. Service is therefore reduced to changing the oil.

Oil change

The oil (approx. 0,3 l) is to be changed every 5 years or at the latest after 400 operating hours.

Disassemble the gear cover (51) by removing the cylinder screws (52) and unscrew the screw plug (44). Place the hoist horizontally and turn so that the oil can drain from the fill hole into a suitable container (approx. 30 minutes). Replenish the gearbox oil. We recommend a mineral oil viscosity class ISO-VG 460, e.g. FINA GIRAN L 460. Finally re-adjust the overload protection device.

Disassemble the gearbox

Attention: The gearbox has oil lubrication

1. Pull the coupling (50) off the gear shaft (35). Loosen screws (52) and remove gear cover (51).
2. Remove screw plug (44) and seal (45).
3. Place gearbox upside down and drain oil from the fill hole into a suitable container.
4. Loosen threaded pin (47), remove ball (46) and unscrew fixing screw (42).
5. Remove cup springs (41).

6. Loosen locking screw (38) and remove locking bolt (39).
7. Loosen snap ring (37), remove bearing plate (33) and ball bearing (36). Remove snap ring (34) and press ball bearing (36) out of bearing plate (33). Remove snap ring (37) from gear shaft (35).
8. Remove friction discs (28) and ring gear (29).
9. Remove planet gears (32), needle bearings (31), stop washers (30) as well as planet gear carrier assy (27) and pinion (26). Pull out gear shaft (35).
10. Remove threaded pin (17).
11. Press out remaining gears in the housing (1) in direction of the flange. Light blows with a rubber hammer in axial direction onto the rim of the housing (flange side) may be helpful to loosen the bearing race (15).
12. Remove planet gears (25), needle bearings (24) and stop washers (23) from planet gear carrier (22).
13. Pull planet gear carrier (22) and pinion (21) out of planet gear carrier (3).
14. Remove ball bearing (20) and bearing race (15) from planet gear carrier (3).
15. Remove snap ring (11) from planet gear carrier (3) and press out planet gear shaft (10).
16. Remove planet gears (7), needle bearings (8), stop washers (6) and spacer rings (9).
15. Remove bearing (5) and packing rings (4).

After cleaning, inspection and replacement of all worn parts re-assembly can be started.

Parts subject to wear are: stop washers (6, 23, 30), needle bearings (8, 24, 31), O-rings and packing rings (4, 16, 18, 43) as well as the seal (45).

Reassemble the gearbox

Reassemble the gearbox in the reverse order strictly in accordance with the sectional drawing.

Special care should be taken for clean and correct installation of planet gears (7) with needle bearings (8) in equal sorting and stop washers (6) as well as spacer rings (9) in the planet gear carrier (3).

The friction discs (28) on either side of the ring gear (29) must be installed oil-soaked (leave in oil for 1 hour before installation).

The exact adjustment of the overload device is only possible when the hoist is completely reassembled. Pre-adjustment of the cup spring (41) is made with the fixing screw (42).

After the exact adjustment has been made, the fixing screw (42) is secured by means of the ball (46) and the threaded pin (47).

6.9 MOTOR

Motor

Under normal conditions the motor is practically maintenance-free. Every 2.1/2 years the bearings are to be inspected, cleaned and repacked half-full with grease. We recommend K 3 N / KL 3 N DIN 51825 / DIN 51502.

Disc brake

Service to the disc brake is reduced to checking and adjusting the brake air gap. The disc brake air gap should be between 0,2 and 0,6 mm (this guarantees a short reaction time and low noise emission). When the wear and tear of the brake lining comes down to the point where the max. possible air gap has finally been reached, it is indispensable to carry out a re-adjustment of the brake (the max. permissible air gaps are shown in the table below).

- 3.1 Remove fan guard M14.
- 3.2 Loosen binding screws B14.
- 3.3 Remove O-ring B62, insert spacer blocks B40 between armature disc B42 and adhesive plate B16 (thickness of the spacer blocks is to be found in the table below).
- 3.4 Tighten screws B31, or - in case of two shaft extensions - nut B35 to an extent as to permit the removal of the spacer blocks B40.
- 3.5 Evenly tighten the binding screws B14. Please tighten first screw placed opposite of the fitting key (for the permissible torque consult the table below).
- 3.6 Tighten screw B31 once more.
- 3.7 Remove spacer blocks B40.
- 3.8 Put on fan guard M14.
- 3.9 Make a test run for checking the brake function.

Attention: Do not allow the brake friction pads to come into contact with lubricant or similar.

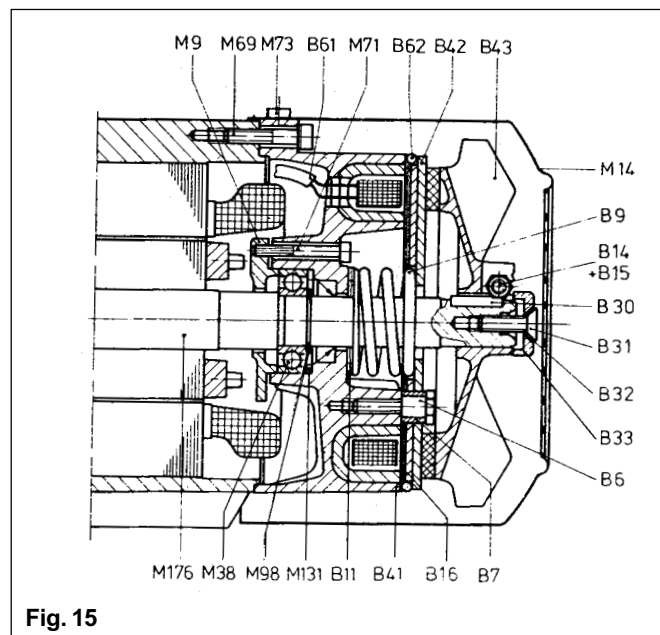

Fig. 15

1	2	3	4	5	6	7	8	9	10	11
Type	Nominal brake torque	Fan B43 with brake lining	Spacer block B40 (mm)	Air gap max. (mm)	Pressure spring B9 colour	Tightening torque for B14	Tightening torque for B6	Adhesive plate B16	Threaded pin B71	Quantity of fitting plate B11
EBF	20,2 Nm	WS 5907	-	0,6	no colour	7 - 9 Nm	7 + 0,5 Nm	no	M 5x80	0

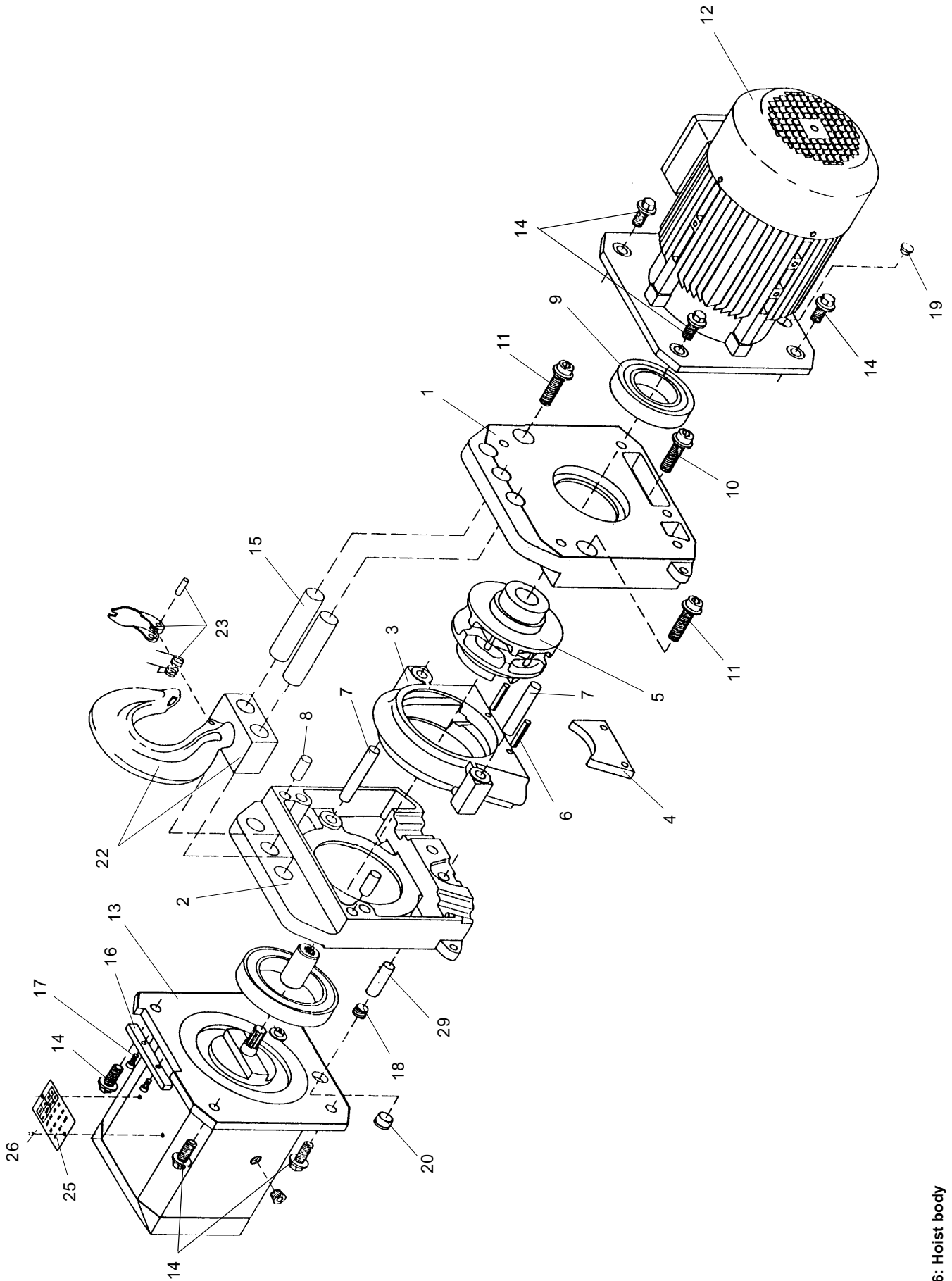
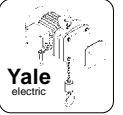

Fig. 16: Hoist body

Yale Electric Chain Hoist CPE



Item No.	Description	Qty.	Yale Part No.									
			CPE / F 16	CPE / F 20	CPE / F 25	CPE / F 30	CPE / F 32	CPE / F 40	CPE / F 50			
1-11	Main frame assy.	1	0609449	0609449	0609449	0609449	0609449	0609449	0609449	0609449	0609449	0609449
1	Housing half - motor side	1	0608972	0608972	0608972	0608972	0608972	0608972	0608972	0608972	0608972	0608972
2	- gearbox side	1	0608974	0608974	0608974	0608974	0608974	0608974	0608974	0608974	0608974	0608974
3	Chain guide	1	0608976	0608976	0608976	0608976	0608976	0608976	0608976	0608976	0608976	0608976
4	Chain stripper	1	0608978	0608978	0608978	0608978	0608978	0608978	0608978	0608978	0608978	0608978
5	Load sheave	1	0609374	0609374	0609374	0609374	0609374	0609374	0609374	0609374	0609374	0609374
6	Roll pin	2	9134001	9134001	9134001	9134001	9134001	9134001	9134001	9134001	9134001	9134001
7	Straight pin	2	9124169	9124169	9124169	9124169	9124169	9124169	9124169	9124169	9124169	9124169
8	Straight pin	2	9124111	9124111	9124111	9124111	9124111	9124111	9124111	9124111	9124111	9124111
9	Ball bearing	1	9151106	9151106	9151106	9151106	9151106	9151106	9151106	9151106	9151106	9151106
10	Cyl. screw	1	9102253	9102253	9102253	9102253	9102253	9102253	9102253	9102253	9102253	9102253
11	Cyl. screw	2	9102254	9102254	9102254	9102254	9102254	9102254	9102254	9102254	9102254	9102254
12	Brake motor - 1 speed	1	0600116	0600116	0600116	0600116	0600116	0600116	0600116	0600116	0600116	0600116
	- 2 speeds	1	0600117	0600117	0600117	0600117	0600117	0600117	0600117	0600117	0600117	0600117
13	Planetary gear	1	0609678	0609678	0608814	0608814	0608814	0609678	0609678	0609678	0609678	0608814
14	Hex. screw	8	9101660	9101660	9101660	9101660	9101660	9101660	9101660	9101660	9101660	9101660
15	Suspension bolt	2	0609388	0609388	0609388	0609388	0609388	0609388	0609388	0609388	0609388	0609388
16	Bolt locking device	1	0609448	0609448	0609448	0609448	0609448	0609448	0609448	0609448	0609448	0609448
17	Cyl. screw	2	9102150	9102150	9102150	9102150	9102150	9102150	9102150	9102150	9102150	9102150
18	Screw plug	2	9110007	9110007	9110007	9110007	9110007	9110007	9110007	9110007	9110007	9110007
19	Screw plug	1	9192000	9192000	9192000	9192000	9192000	9192000	9192000	9192000	9192000	9192000
20	Screw plug	1	9192003	9192003	9192003	9192003	9192003	9192003	9192003	9192003	9192003	9192003
21	Screw plug	1	9192002	9192002	9192002	9192002	9192002	9192002	9192002	9192002	9192002	9192002
22-23	Suspension hook assy.	1	0609393	0609393	0609393	0609393	0609393	0609393	0609393	0609393	0609393	0609393
23	Safety latch kit	1	0408671	0408671	0408671	0408671	0408671	0408671	0408671	0408671	0408671	0408671
25	Identity plate - 1 speed	1	0609614	0609996	0609456	0609744	0609744	0609614	0609997	0609456	0609997	0609456
	- 2 speeds	1	0609615	0609998	0609457	0609745	0609745	0609615	0609999	0609457	0609999	0609457
26	Grooved nail	2	9128004	9128004	9128004	9128004	9128004	9128004	9128004	9128004	9128004	9128004
-	Capacity decal	1	0609694	0600002	0609695	0609696	0609696	0609682	0600001	0609511	0609692	0609511
-	Nameplate	2	0609692	0609692	0609692	0609692	0609692	0609692	0609692	0609692	0609692	0609692
29	Chain anchor bolt	1	-	-	-	-	-	0608855	0608855	0608855	0608855	0608855



Yale Electric Chain Hoist CPE

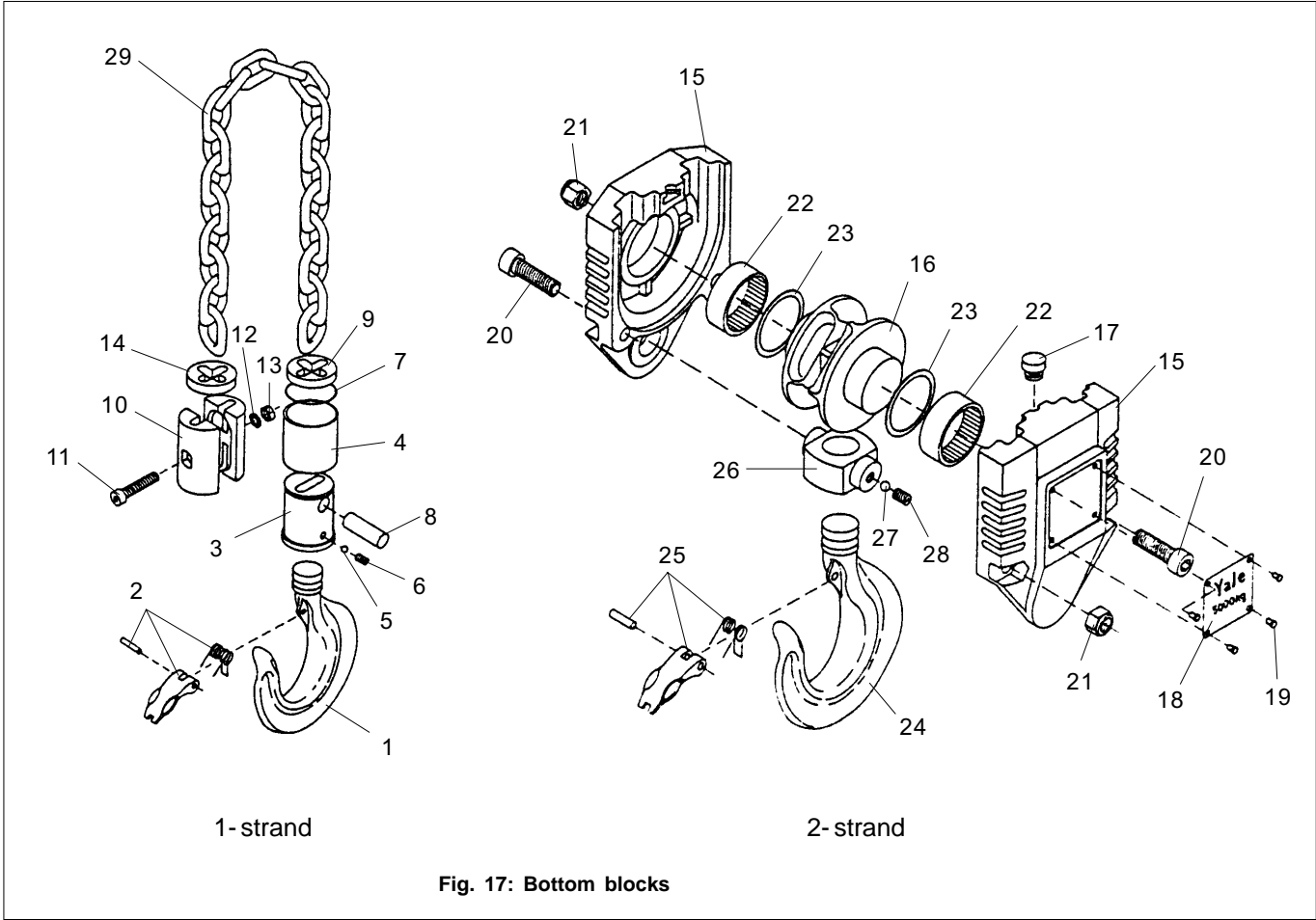

Fig. 17: Bottom blocks

Item No.	Description	Qty.	CPE / F 16 CPE / F 20 CPE / F 25 CPE / F 30
1-8	Bottom block assy. 1600 kg	1	0609684
	Bottom block assy. 2000 kg	1	0609993
	Bottom block assy. 2500 kg	1	0609677
	Bottom block assy. 3000 kg	1	0609909
1-2	Load hook assy.	1	0408430
2	Safety latch kit	1	0408671
3	Load hook coupling	1	0608851
4	Swivel tube 1600 kg	1	0609683
	Swivel tube 2000 kg	1	0600003
	Swivel tube 2500 kg	1	0609399
	Swivel tube 3000 kg	1	0609908
5	Ball set (15 pcs. Ø 5)	1	0404767
6	Threaded pin	1	9114030
7	Snap ring	1	9139020
8	Chain bolt	1	0608855
9	Buffer	1	0609734
10-14	Chain end stop assy.	1	0609995
10	Chain end stop half	2	0608867
11	Cyl. screw	1	9102019
12	Lockwasher	1	9122032
13	Hex. nut	1	9115014
14	Buffer	1	0609734

Item No.	Description	Qty.	CPE / F 32 CPE / F 40 CPE / F 50
15-23	Bottom block assy. 3200 kg	1	0609681
	Bottom block assy. 4000 kg	1	0609994
	Bottom block assy. 5000 kg	1	0609510
15	Swivel half	2	0609495
16	Idler sheave	1	0609505
17	Buffer	1	0601704
18	Capacity plate 3200 kg	2	0609682
	Capacity plate 4000 kg	2	0600001
	Capacity plate 5000 kg	2	0609511
19	Grooved nail Ø 3 x 4	8	9128004
20	Cyl. screw	2	9102053
21	Hex. nut	2	9115118
22	Needle bearing	2	9153083
23	Spacer	2	9121218
24-28	Load hook assy.	1	0408434
25	Safety latch kit	1	0408672
26-28	Crosshead assy.	1	0404850
27	Ball set (16 pcs. Ø 6)	1	0404799
28	Threaded pin	1	9114184
29	Load chain (specify length)		6109488

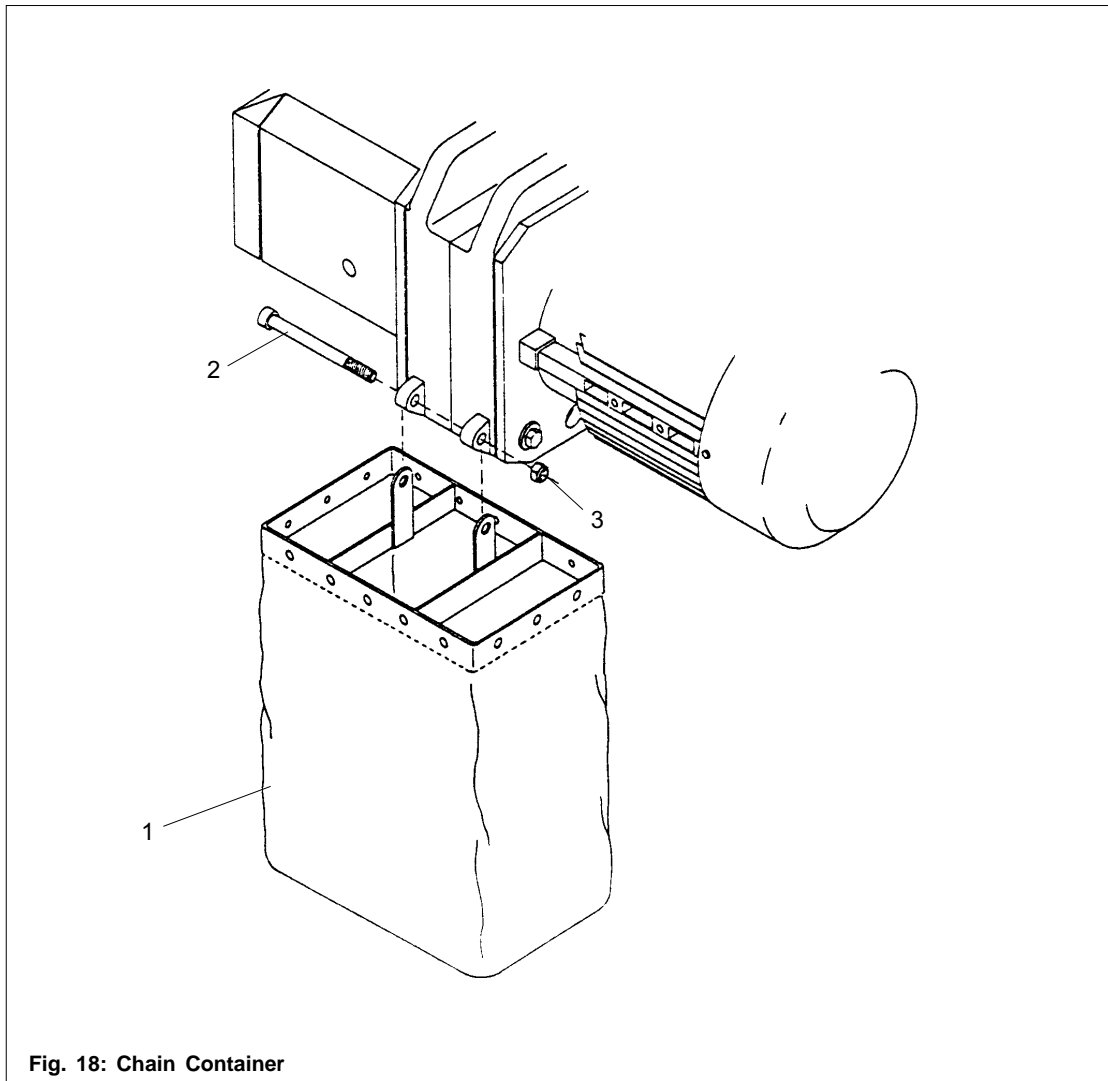
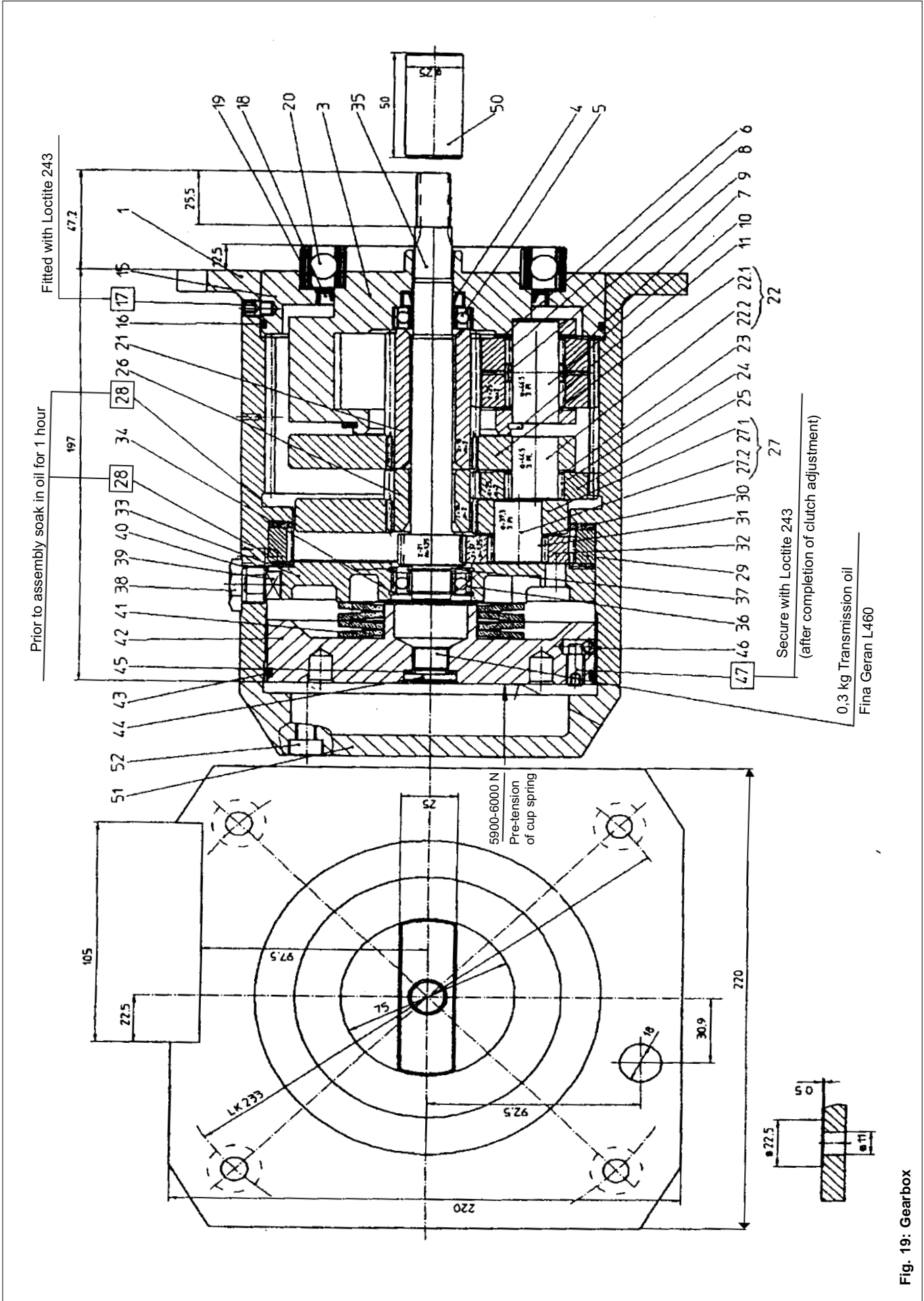
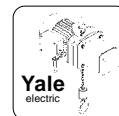

Fig. 18: Chain Container

Item No.	Description	Qty.	Yale Part No. all models
1	Chain container assy for 13 m linear chain length	1	6109467
1	Chain container assy for 21 m linear chain length	1	6109468
2	Cyl. screw	1	9102255
3	Hex. nut	1	9115098



Yale Electric Chain Hoist CPE



Item No.	Description	Qty.	Model CPE 30-5	Item No.	Description	Qty.	Model CPE 30-5
-	Planet gearbox assy.	1	0600230	27.2	Planet gear shaft	3	0600253
1	Gearbox housing	1	0600237	28	Friction disc	2	0600254
2	Ring	1	0600238	29	Ring gear	1	0600255
3	Planet gear carrier	1	0600239	30	Stop washer	3	9153043
4	Packing ring	1	9172110	31	Needle bearing	3	9153090
5	Bearing	1	9150043	32	Planet gear	3	0600171
6	Stop washer	6	9153043	33	Bearing plate	1	0600256
7	Planet gear	3	0600240	34	Snap ring	2	9130034
8	Needle bearing	6	9153090	35	Gear shaft	1	0600257
9	Spacer ring	3	0600241	36	Ball bearing	1	9150043
10	Planet gear shaft	3	0600242	37	Snap ring	2	9129029
11	Snap ring	1	9129070	38	Locking screw	1	0600258
13	Ring	1	0600243	39	Locking bolt	1	0600259
14	Snap ring	1	9129071	40	O-ring	1	9171169
15	Bearing race	1	0600244	41	Cup spring	4	9120041
16	O-ring	1	9171352	42	Fixing screw	1	0600260
17	Threaded pin	1	9114134	43	O-ring	1	9171170
18	Packing ring	1	9172112	44	Screw plug	1	9110052
19	Washer	1	9121234	45	Seal	1	9179004
20	Ball bearing	1	9151101	46	Ball	1	9159011
21	Pinion	1	0600245	47	Threaded pin	1	9114136
22	Planet gear carrier assy.	1	0600246	48	Fitting plate	1	9121056
22.1	Carrier disc	1	0600247	50	Coupling	1	0608879
22.2	Planet gear shaft	3	0600248	51	Gear box cover	1	0600262
23	Stop washer	3	9153043	52	Screw	4	9102019
24	Needle bearing	3	9153090				
25	Planet gear	3	0600249				
26	Pinion	1	0600250				
27	Planet gear carrier assy.	1	0600251				
27.1	Carrier disc	1	0600252				

Attention: When ordering spare parts always indicate serial number and mfg. year of hoist

Yale Electric Chain Hoist CPE

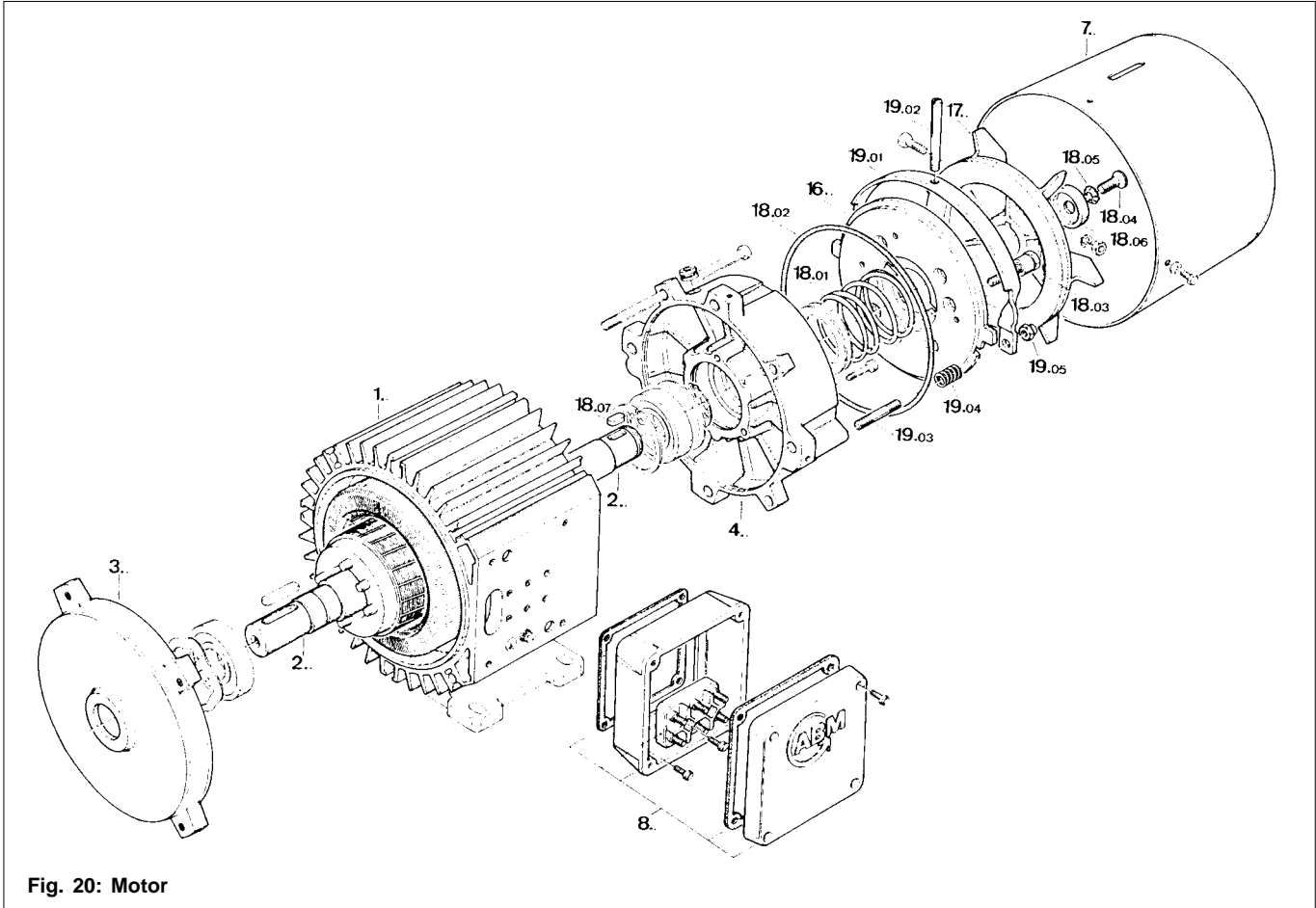

Fig. 20: Motor

Item No.	Description	Qty.	CPE 1-speed	CPEF 2-speed
-	Motor assy.	1	0600116	0600117
1 ..	Stator	1	0600185	0600196
2 ..	Rotor	1	0600186	0600197
3 ..	Bearing plate, A-side	1	0600187	0600187
4 ..	Bearing plate, B-side	1	0600188	0600188
7 ..	Fan cover	1	0600189	0600189
8 ..	Terminal box assy. (board, box, box cover box seal)	1	0600190	0600190
9 ..	Rectifier	1	0600110	0600110
16 ..	Armature disc	1	0600113	0600113
17 ..	Brake fan	1	0600112	0600112
18 ..	Fitting parts set for mounting the brake (brake spring, O-ring, cap screw, washers, fitting key)	1	0600194	0600194
19 ..	Manual brake release system (optional)	1	0600195	0600195

Attention: When ordering spare parts always indicate serial number and mfg. year of hoist

Yale Electric Chain Hoist CPE

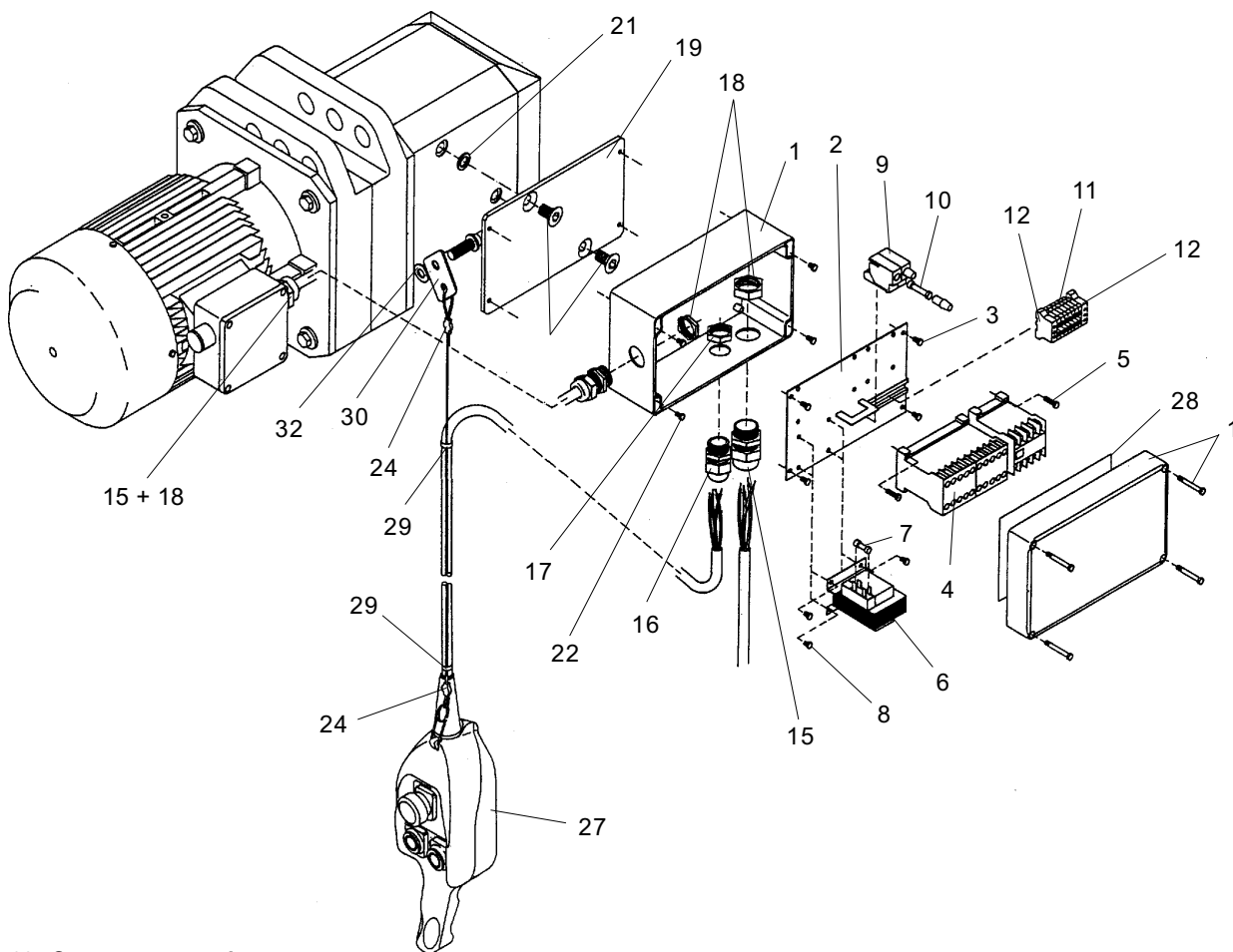
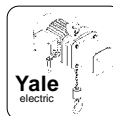

Fig. 22: Contactor control

Item No.	Description	Qty.	Yale Part No. all models
1	Housing	1	0609810
2	Mounting plate	1	0609792
3	Screw	4	9108018
4	Reversing starter	1	0609558
5	Screw	4/8*	9107005
6	Transformer	1	0719737
7	Fine-wire fuse	1	9190126
8	Screw	4	9107032
9	Fuse carrier	2	0609808
10	Fine-wire fuse	2	9190128
11	Terminal	6/7*	0609811
12	PE conductor terminal	2	0609812
	Name tag 1	1	0609813
	Name tag 2	1	0609814
	Name tag 3	1	0609815
	Name tag 4	1	0609816
	Name tag L1	1	0609817
	Name tag L2	1	0609818
	Name tag L3	1	0609819
	Name tag PE	1	0609820
	Name tag	3	0609821
	Name tag F5	1	0609822
	Name tag F6	1	0609823

Item No.	Description	Qty.	Yale Part No. all models
15	Screw fitting	3	9184082
16	Screw fitting	1	9184081
17	Counter-nut	1	9184085
18	Counter-nut	3	9184086
19	Plate	1	0609788
20	Screw	2	9103013
21	Washer	2	9121001
22	Cyl. screw	4	9107023
23	Connecting cable (CPE only)	1*	0609828
	Connecting cable (CPEF only)	1*	0609829
24	Rope clamp	2	0605355
25	Tension relief wire	1	0609561
26	Control cable (CPE only)	1	0606562
	Control cable (CPEF only)	1*	0609563
27	Control switch (CPE only)	1	0609566
	Control switch (CPEF only)	1	0609567
28	Wiring diagram (CPE only)	1	0609571
	Wiring diagram (CPEF only)	1	0609572
29	Tape	5	9181113
30	Fastener	1	0608882
31	Hex. Screw	1	9101661
32	Washer	1	9121006
33	Contactors	1*	0609574



Yale Electric Chain Hoist CPE

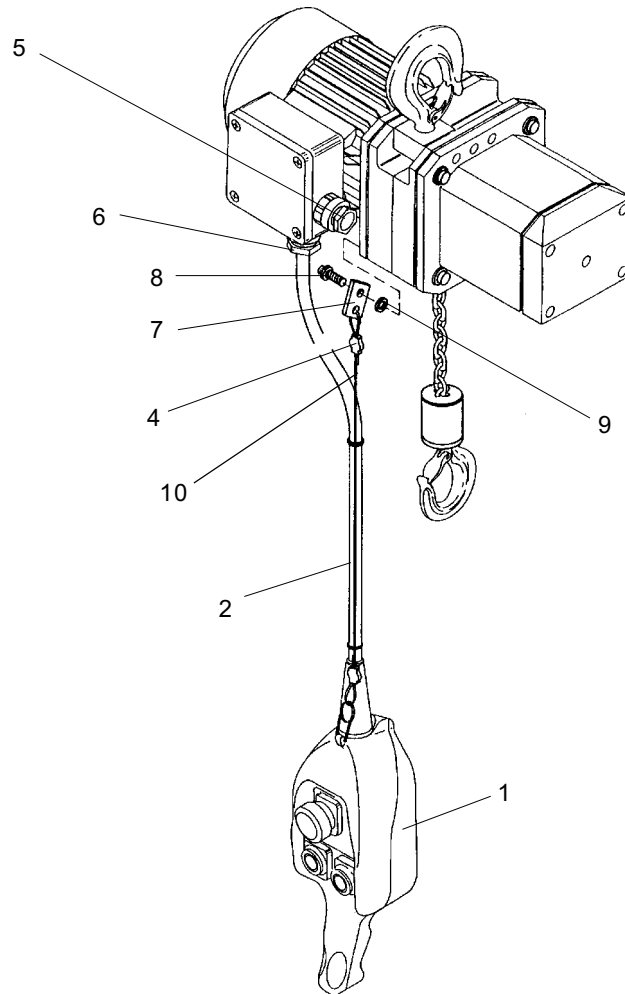

Fig. 23: Direct control

Item No.	Description	Qty.	CPE 1-speed	CPEF 2-speed
1	Pendant control assy with emergency stop	1	0609454	0609455
2	Control cable (specify length)	-	9062407	9062407
3	Wiring diagram	1	0609631	0609632
4	Clamp	2	0605355	0605355
5	Screw fitting	1	9184082	9184082
6	Screw fitting	1	9184084	9184084
7	Fastener	1	0608882	0608882
8	Hex. screw	1	9101661	9101661
9	Washer	1	9121006	9121006
10	Strain relief (specify length)	-	9093001	9093001

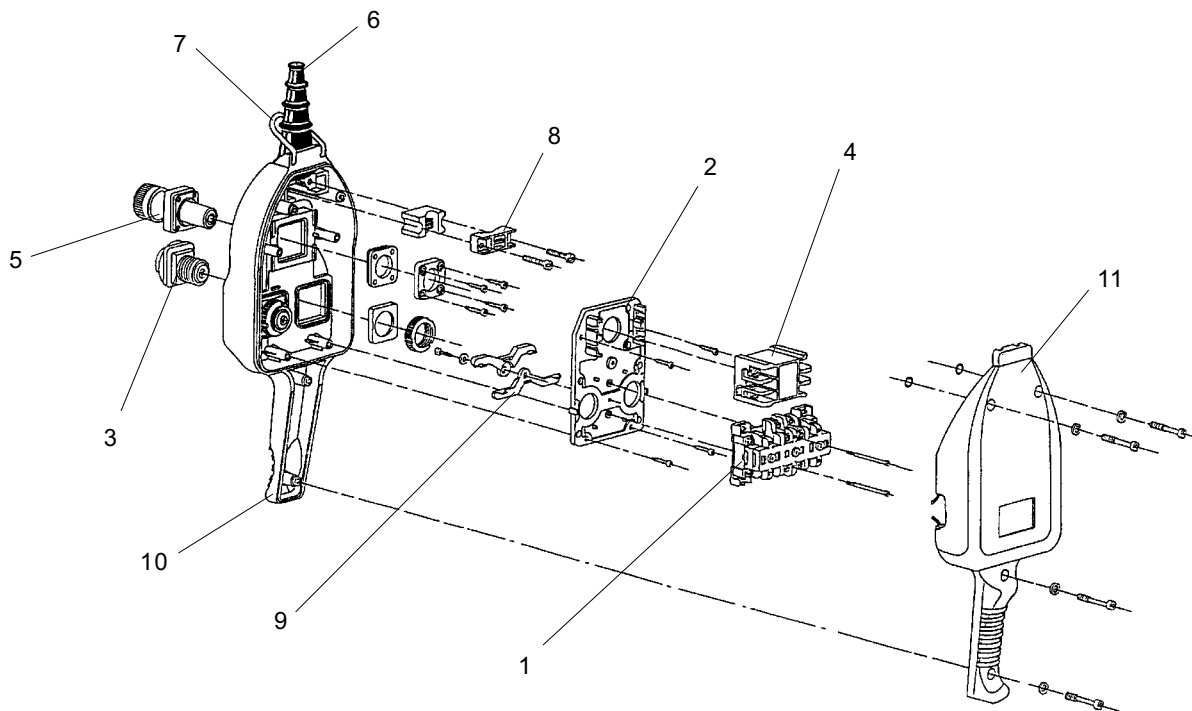

Fig. 24: Pendant switch for direct control

Item No.	Description	Qty.	CPE 1-speed	CPEF 2-speed
-	Pendant control assy. with emergency stop	1	0609454	0609455
1	Contact element	1	0609686	0609687
2	Carrier for contact element	1	0609965	0609965
3	Lowering button DN	1	0609966	0609967
	Lifting button UP	1	0609968	0609969
4	Contact element emerg. stop	1	0609978	0609978
5	Emergency stop button	1	0609977	0609977
6	Rubber bushing	1	0609970	0609970
7	Loop for tension relief device	1	0609971	0609971
8	Clamping piece	1	0609972	0609972
9	Interlocking lever	1	0609973	0609973
10	Front housing	1	0609974	0609974
11	Rear housing	1	0609975	0609975

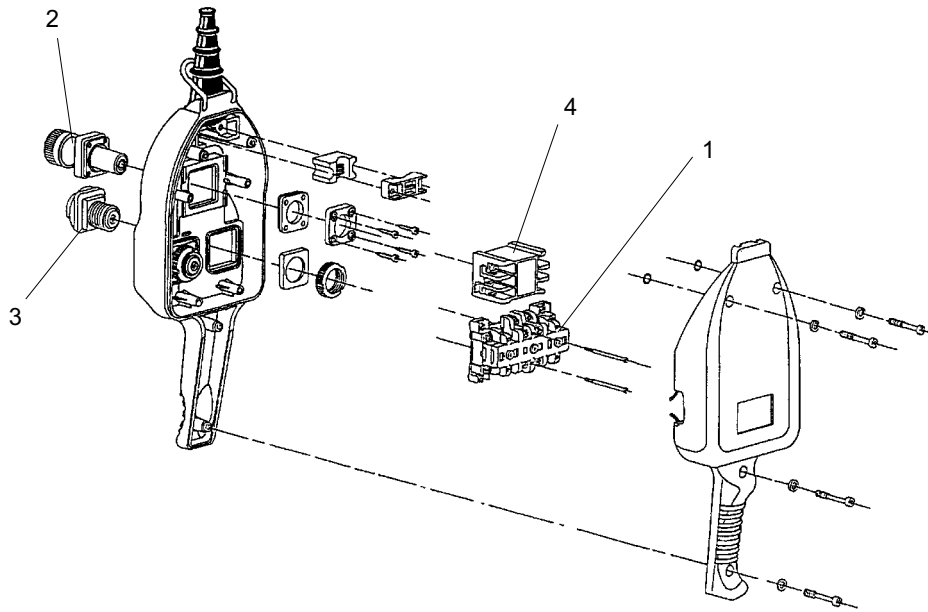

Fig. 25: Pendant switch for contactor control

Item No.	Description	Qty.	CPE 1-speed	CPEF 2-speed
-	Pendant control assy. with emergency stop	1	0609566	0609567
1	Contact element	1	0609980	0609981
2	Emergency stop button	1	0609984	0609984
3	Lowering button DN	1	0609985	0609986
	Lifting button UP	1	0609987	0609988
4	Contact element emerg. stop	1	0609982	0609983

Yale Electric Chain Hoist CPE

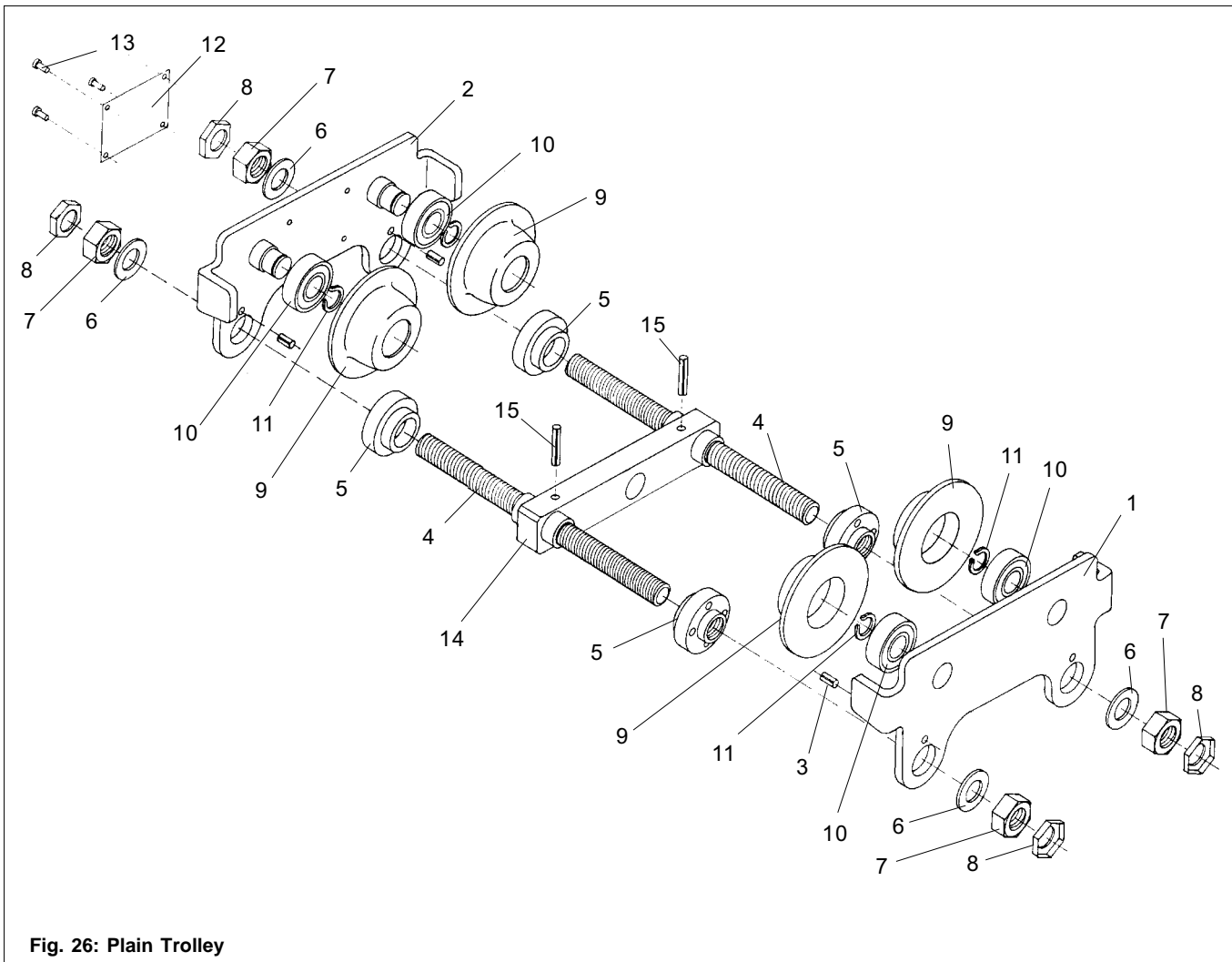
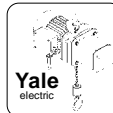

Fig. 26: Plain Trolley

Item No.	Description	Qty.	Yale Part No. all models
1	Side plate	1	0559163
2	Side plate	1	0559167
3	Roll pin	4	9134120
4	Crossbar - beam range A	2	0559169
	Crossbar - beam range B	2	0559170
5	Round nut	4	0559168
6	Washer	4	9121213
7	Hex. nut	4	9115156

Item No.	Description	Qty.	Yale Part No. all models
8	Locking nut	4	9115155
9	Trolley wheel	4	0508210
10	Ball bearing	8	9151079
11	Snap ring	4	9129003
12	Identity plate	1	0559869
13	Grooved nail	4	9128004
14	Centre traverse	1	0559353
15	Roll pin	2	9134002

Yale Electric Chain Hoist CPE

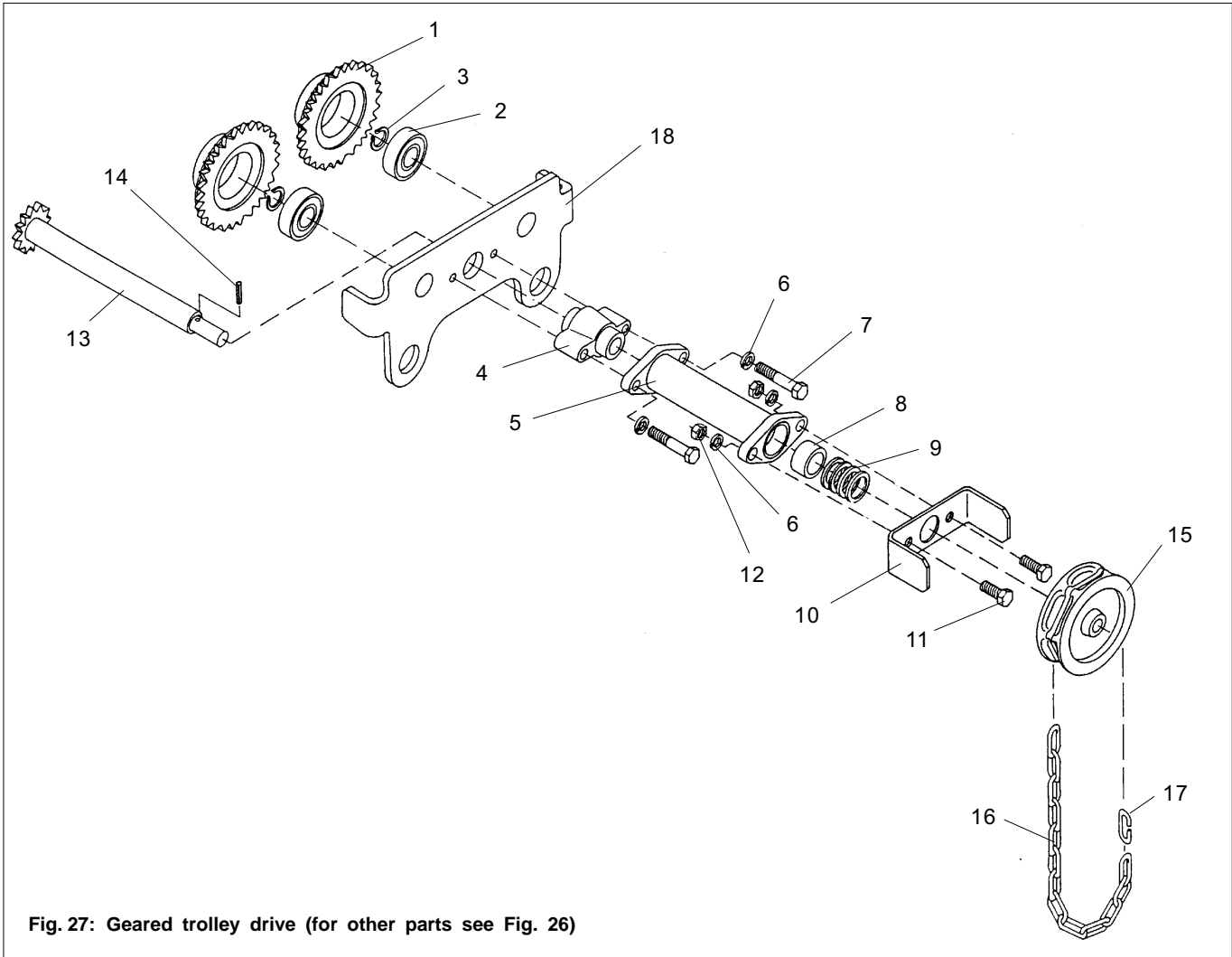

Fig. 27: Geared trolley drive (for other parts see Fig. 26)

Item No.	Description	Qty.	Yale Part No. all models
1	Geared trolley wheel	2	0508214
2	Ball bearing	8	9151079
3	Snap ring	4	9129003
4	Support	1	0508229
5	Spacer tube	1	0719111
6	Lockwasher	4	9122016
7	Hex. screw	2	9101050
8	Bushing	1	0102503
9	Spacer	4	9121205

Item No.	Description	Qty.	Yale Part No. all models
10	Hand chain guide	1	0558062
11	Hex. screw	2	9101014
12	Hex. nut	2	9115148
13	Drive shaft	1	0719671
14	Roll pin	1	9134052
15	Hand chain wheel	1	0558061
16	Hand chain (specify length)		4307654
17	Connecting link	1	0404733
18	Side plate	1	0559165

Yale Electric Chain Hoist CPE

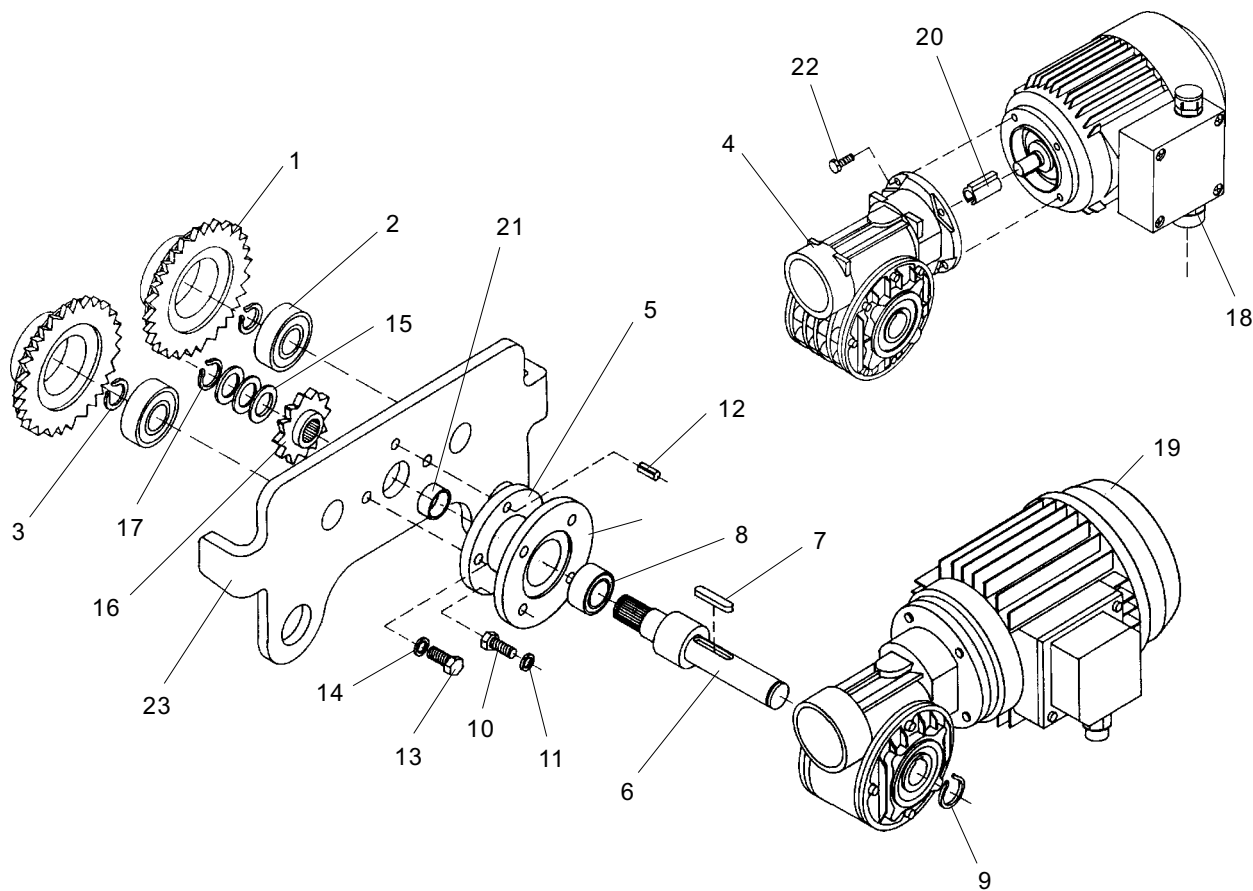
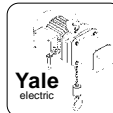

Fig. 28: Electric trolley drive (for other parts see Fig. 26)

Item No.	Description	Qty.	Yale Part No. all models
1	Geared trolley wheel	2	0508214
2	Ball bearing	8	9151079
3	Snap ring	4	9129003
4	Worm gear	1	0719764
5	Flange	1	0719371
6	Drive shaft	1	0719372
7	Fitting key	1	9131072
8	Needle bearing	1	9153077
9	Snap ring	1	9129016
10	Hex screw	4	9101170
11	Lockwasher	4	9122003
12	Roll pin	1	9134080

Item No.	Description	Qty.	Yale Part No. all models
13	Hex. nut	2	9101014
14	Lockwasher	2	9122004
15	Spacer	7	9121215
16	Pinion	1	0719373
17	Snap ring	1	9123038
18	Screw fitting	1	9184082
19	Brake motor - 1 speed	1	0609586
	- 2 speeds	1	0609587
20	Reducing sleeve	1	0719868
21	Bushing	1	0719870
22	Hex. screw	4	9101439
23	Side plate	1	0559165

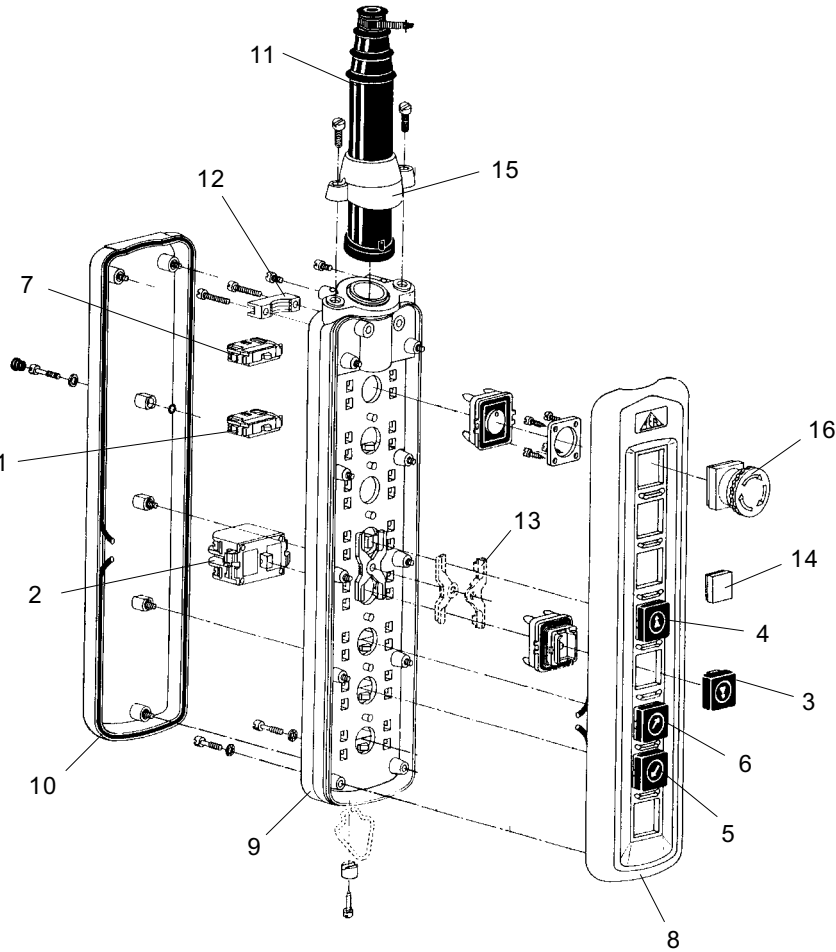

Fig. 29: Pendant switch for electric hoist with electric trolley (direct and contactor control)

Item No.	Description	Qty.	Pendant switch for direct control				Pendant switch for contactor control			
			Hoist 1G Trolley 1G	Hoist 2G Trolley 2G	Hoist 2G Trolley 1G	Hoist 1G Trolley 2G	Hoist 1G Trolley 1G	Hoist 2G Trolley 2G	Hoist 2G Trolley 1G	Hoist 1G Trolley 2G
1-18	Control switch assy.	1	0609610	0609611	0609832	0609833	0609612	0609613	0609806	0609807
1	Contact element hoist	1	0609686	0609687	0609687	0609686	0600032	0600034	0600034	0600032
	Contact element hoist	1	-	-	-	-	0600033	-	-	0600033
2	Contact element trolley	1	0600022	0600029	0600022	0600029	0600032	0600034	0600032	0600034
	Contact element trolley	1	-	-	-	-	0600033	-	0600033	-
3	▼ -button DN, hoist	1	0600023	0600030	0600030	0600023	0600023	0600030	0600030	0600023
4	▲ -button UP, hoist	1	0600024	0600031	0600031	0600024	0600024	0600031	0600031	0600024
5	◀ -button LEFT, trolley	1	0600023	0600030	0600023	0600030	0600023	0600030	0600023	0600030
6	▶ -button RIGHT, trolley	1	0600024	0600031	0600024	0600031	0600024	0600031	0600024	0600031
7	Contact element em. stop	1/2*		0609978				0600032		
8-10	Housing assy. without contacts and buttons	1		0600028				0600035		
8	Front housing	1				on request				
9	Housing centre part	1				on request				
10	Rear housing	1				on request				
11	Rubber bushing	1				0600025				
12	Clamping piece	1				0609972				
13	Interlocking lever	2				0609973				
14	Dust cap	1				0600026				
15	Rubber bushing support	1				0600027				
16	Emergency stop button	1				0609977				

* for contactor control only

1G = 1 speed; 2G = 2 speeds

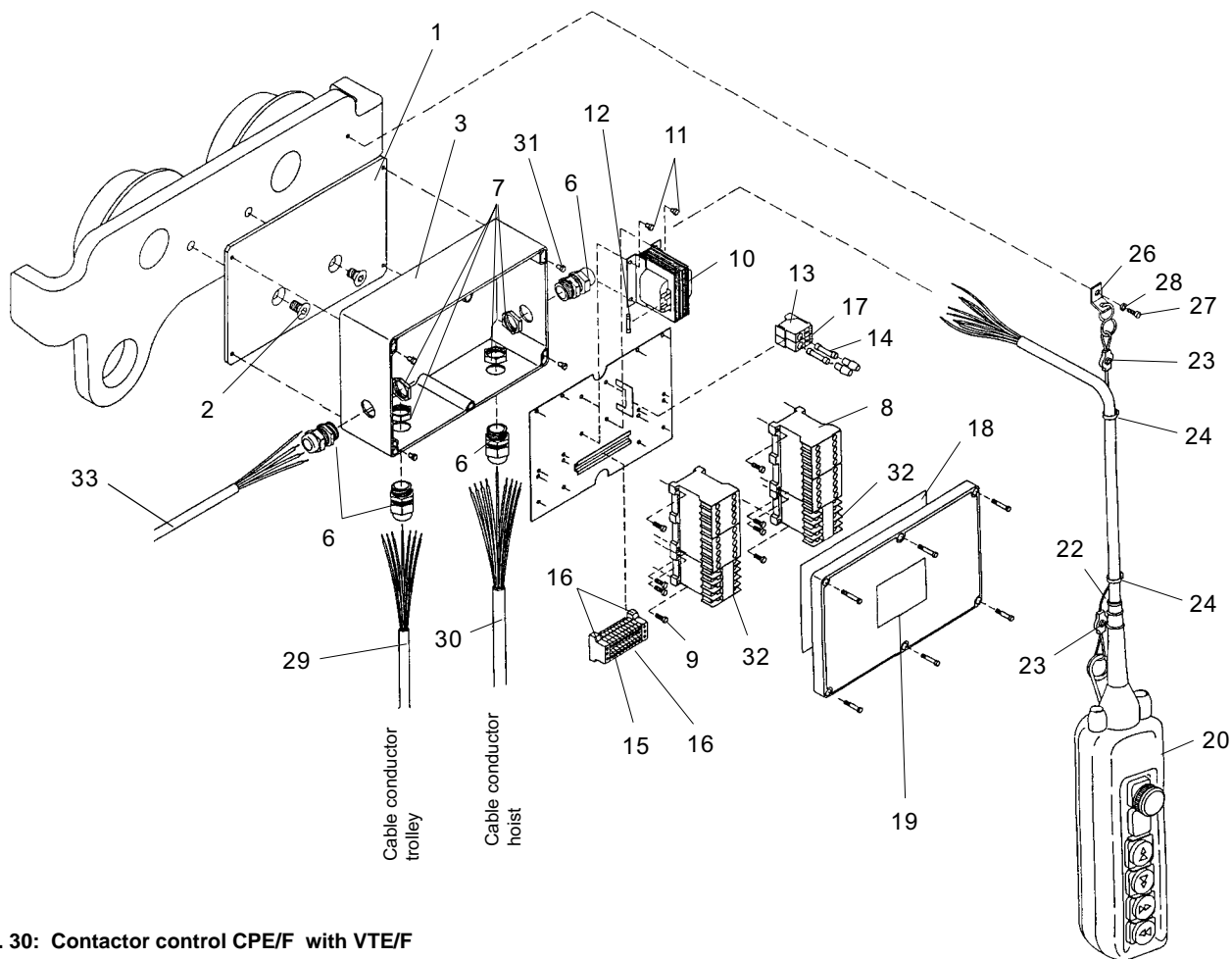

Fig. 30: Contactor control CPE/F with VTE/F

Item No.	Description	Qty.	Yale Part No. all models
1	Plate	1	0719732
2	Screw	2	9103005
3	Housing	1	0719722
4	Mounting plate	1	0719721
5	Screw	4	9108018
6	Screw fitting	4	9184082
7	Counter-nut	4	9184086
8	Contactor	2	0609558
9	Screw	8	9107005
10	Transformer	1	0719760
11	Screw	4	9107011
12	Fine-wire fuse	1	9190129
13	Fuse terminal	2	0609808
14	Fine-wire fuse	2	9190130
15	Terminal	8	0609811
16	Ground terminal	2	0609812
17	Name tag 1	1	0609813
	Name tag 2	1	0609814
	Name tag 3	1	0609815
	Name tag 5	1	0609848
	Name tag 6	1	0609849
	Name tag L1	1	0609817
	Name tag L2	1	0609818
	Name tag L3	1	0609819
	Name tag PE	1	0609820

Item No.	Description	Qty.	Yale Part No. all models
18	Name tag	3	0609821
	Name tag F5	1	0609822
	Name tag F6	1	0609823
	Wiring diagram CPE+VTE	1	0609854
	Wiring diagram CPEF+VTE	1	0609856
	Wiring diagram CPE+VTEF	1	0609855
	Wiring diagram CPEF+VTEF	1	0609853
19	Identity plate	1	0719680
20	Control switch CPE+VTE	1	0609612
	Control switch CPEF+VTE	1	0609806
	Control switch CPE+VTEF	1	0609807
	Control switch CPEF+VTEF	1	0609613
21	Control cable (for 3 m lift)	1	0609899
22	Strain relief cord (2,4 m)	1	9093001
23	Rope clamp	2	0605355
24	Tape (specify length)		9181113
25	S-hook	1	0717029
26	Support	1	0719742
27	Cyl. screw	1	9102026
28	Lockwasher	1	9122031
29	Cable conductor trolley	1	0609898
30	Cable conductor hoist	1	0609897
31	Screw	4	9107023
32	Contactor (2nd speed only)	1/2*	0609574
33	Power supply cable	1	-

* only CPEF + VTEF



Yale Electric Chain Hoist CPE

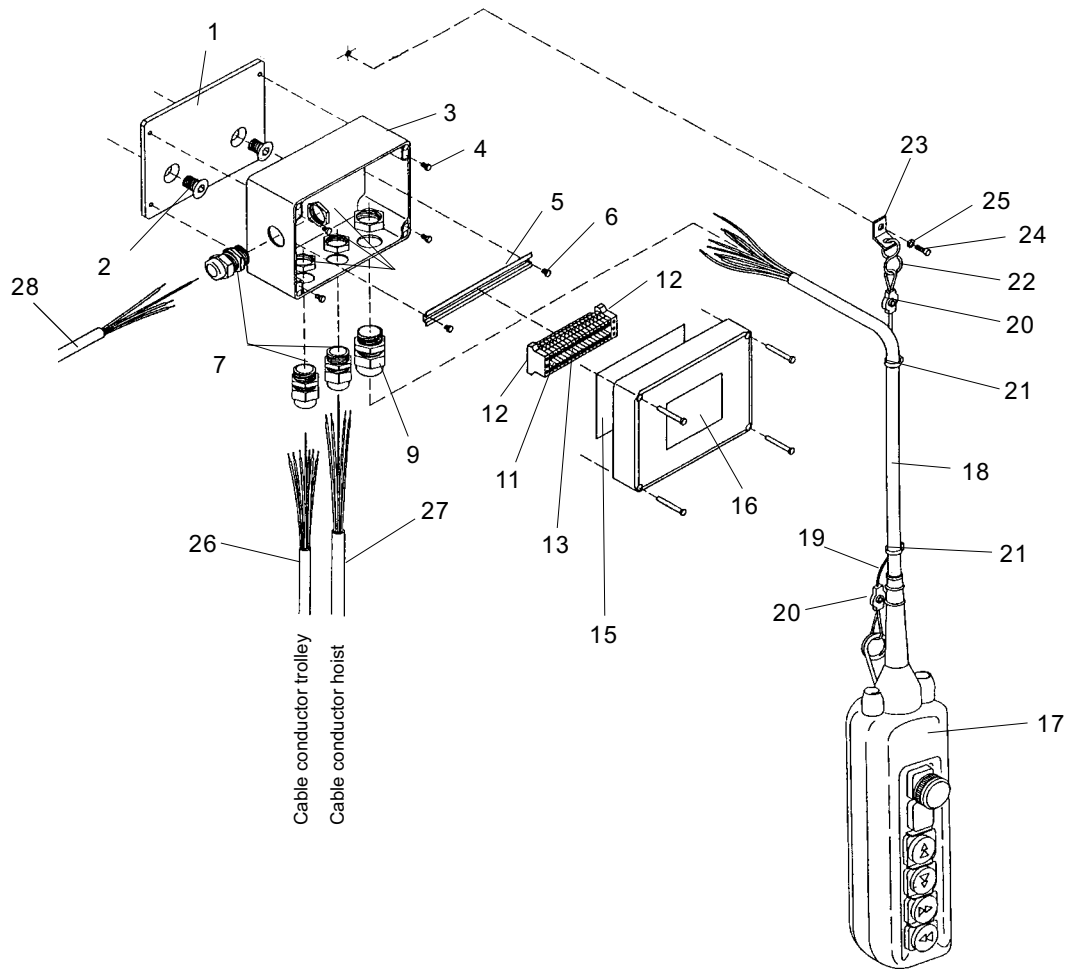
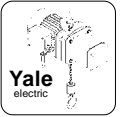

Fig. 31: Direct control CPE/F with VTE/F

Item No.	Description	Qty.	Yale Part No. all models
1	Plate	1	0719741
2	Screw	2	9103005
3	Housing	1	0609878
4	Screw	4	9107023
5	Carrier	1	0609877
6	Screw	2	9108018
7	Screw fitting	3	9184082
8	Counter-nut	3	9184086
9	Screw fitting	1	9184088
10	Counter-nut	1	9184087
11	Terminal	11	0609811
12	Ground terminal	2	0609812
13	Name tag 1	1	0609813
	Name tag 2	1	0609814
	Name tag 3	1	0609815
	Name tag 4	1	0609816
	Name tag 5	1	0609848
	Name tag 9	1	0609872
	Name tag 10	1	0609873
	Name tag 11	1	0609874
	Name tag L1	1	0609817
	Name tag L2	1	0609818
	Name tag PE	1	0609819
	Name tag	3	0609821

Item No.	Description	Qty.	Yale Part No. all models
15	Wiring diagram CPE + VTE	1	0609882
	Wiring diagram CPEF + VTE	1	0609883
	Wiring diagram CPE + VTEF	1	0609884
	Wiring diagram CPEF + VTEF	1	0609885
15	Name plate	1	0719680
17	Control switch CPE + VTE	1	0609610
	Control switch CPEF + VTE	1	0609832
	Control switch CPE + VTEF	1	0609833
	Control switch CPEF + VTEF	1	0609611
18	Control cable for 3 m lift	1	0609890
19	Strain relief cord (2,4 m)	1	9093001
20	Clamp	2	0605355
21	Tape (specify length)		9181113
22	S-hook	1	0717029
23	Support	1	0719742
24	Cyl. screw	1	9102026
25	Lockwasher	1	9122031
26	Cable conductor trolley	1	0609879
27	Cable conductor hoist	1	0609888
28	Power supply cable	1	---
	Control cable (m) CPE+VTE	1	9062403
	Control cable (m) CPEF+VTEF	1	9062403
	Strain relief cord (specify length)		9093001

Yale Electric Chain Hoist CPE



EC DECLARATION OF CONFORMITY
in accordance with Machinery Directive 98/37/EEC (Appendix II A)

We,

Yale Industrial Products GmbH
D-42549 Velbert, Am Lindenkamp 31

hereby declare, that the design, construction and commercialized execution of the below mentioned machine complies with the essential health and safety requirements of the EC Machinery Directive. The validity of this declaration will cease in case of any modification or supplement not being agreed with us previously. Furthermore, validity of this declaration will cease in case that the machine will not be operated correctly and in accordance with the operating instructions and/or not be inspected regularly.

Machine description: Electric chain hoist CPE/F
Mod. CPE/F 16-8, Mod. CPE/F 20-8, Mod. CPE/F 25-5,
Mod. CPE/F 30-5, Mod. CPE/F 32-4, Mod. CPE/F 40-4,
Mod. CPE/F 50-2
Capacity 1600 - 5000 kg

Machine type: Electric chain hoist

Serial number: from manufacturing year 1/95
(Serial numbers for the individual capacities/models are registered
in the production book with the remark CE-sign)

**Relevant
EC Directives:** EC Machinery Directive 98/ 37/EEC

**Transposed harmonised
standards in particular:** EN 292, part 1 (safety of machines)
EN 292, part 2 (safety of machines)
EN 349 (safety of machines)
EN 818, part 1 (round link chain)
EN 818, part 4 (round link chain)

**Transposed (either complete
or in extracts) national
standards and technical
specifications in particular:** FEM 9.671; DIN 5684 (Lastketten)
FEM 9.681 (Fahrmotoren)
FEM 9.682 (Hubmotoren)
FEM 9.755 (Betriebsdauer)
FEM 9.511 (Triebwerkseinstufung)
DIN 15018 (Krane)
DIN 15400 (Lasthaken für Hebezeuge)
DIN 15404 (Lasthaken für Hebezeuge)
VDE 0100 / Teil 726; VDE 0113 / EN 60204
BGV D6 (Krane)
BGV D8 (Winden, Hub- und Zuggeräte)
VBG 9.a (Lastaufnahmemittel)
ZH 1/27 (Prüfung von Kranen)
ZH1/25 (Prüfung von Hubgeräten)

Quality assurance: DIN EN ISO 9001 (Certificate Registration No.: 151)

**Date / Manufacturer's
authorized signature:**

20.09.2002



Identification of the signee:

Dipl.-Ing. Andreas Oelmann
Manager Quality Assurance

**Quality engineered
and performance tested -
recognisably Yale[®]**